

FIBERGLASS CONDUIT SYSTEM FOR

ABOVE GROUND

applications



FRE
COMPOSITES®

F I R S T I N T H E F I E L D

®



FRE Composites' plants produce North America's highest quality fiberglass conduit products, ready for shipment worldwide. These plants house up-to-date automated filament winding equipment, and contains plenty of warehousing capacity, both indoors and outdoors.

FRE
COMPOSITES®

F I R S T I N T H E F I E L D

®

OUR VISION

At FRE Composites, we have the experience, having manufactured our first fiberglass products as far back as 1958. Today, the company has skilled and experienced workforce operating two (2) plants and exporting product to numerous countries worldwide.

Currently, FRE Composites is focused exclusively on the design, engineering and production of composite filament-wound fiberglass conduit products and accessories. However, in addition to core products serving electric, telecom, water and wastewater utilities, and transportation industries, FRE Composites has engineered and produced highly specialized products for use in space exploration made from carbon fibers and other exotic materials, such as rocket launch tubes and the main structure of the CANADARM robotic arm, which is used by NASA's Space Shuttle to manipulate payloads in space. The CANADARM was also used to assist in the construction of the International Space Station, and in 2005, a CANADARM system attached to the International Space Station successfully assisted in the first in-orbit repair of the Space Shuttle Discovery.

Our 100,000 sq.ft. plant in Canada and our 50,000 sq. ft. plant in the United States have the capacity to accommodate high production requirements while maintaining substantial flexibility to foster to our growing customer base needs. Although we are the only source of FRE® trademarked conduit, it's no secret that we are not the only suppliers of fiberglass conduit in North America. Considering that you have choices, why should you do business with us ?

EXPERIENCE COMPETENCE COMMITMENT

Quality

Our products are engineered to exacting standards, and are produced to consistent quality standards to provide superior life expectancy. Design performance and quality control always have been, and always will be, our number one priority.

Experience

Our long experience has taught us how to design and to build our products right: First in the Field®.

Production capacity

FRE Composites operates the largest production facility to produce fiberglass conduit in North America, which enables us to produce large volumes of product within tight delivery deadlines while being flexible to service ongoing requirements of numerous projects. We value distribution.

Distribution

FRE Composites has always joined forces with distribution to promote its product lines. FRE® fiberglass conduit products are available in all popular sizes from stocking distributors from coast to coast in both Canada and the United States.

Service

We are organized to provide courteous and professional customer service in Chinese, English, French, Italian, Russian and Spanish. To better serve clients beyond continental North America, we are in the process of adding service capabilities in several additional languages.

We are eager to serve you professionally and courteously, supplying you with high quality conduit systems in accordance with your requirements.

No job is too small or too big.

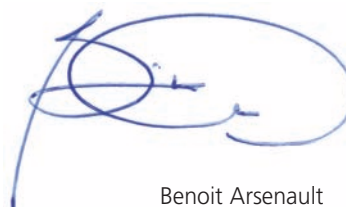

Benoit Arsenault
President

FRE® Above Ground Conduit System

SYSTEM

DIMENSIONS

WALL THICKNESSES

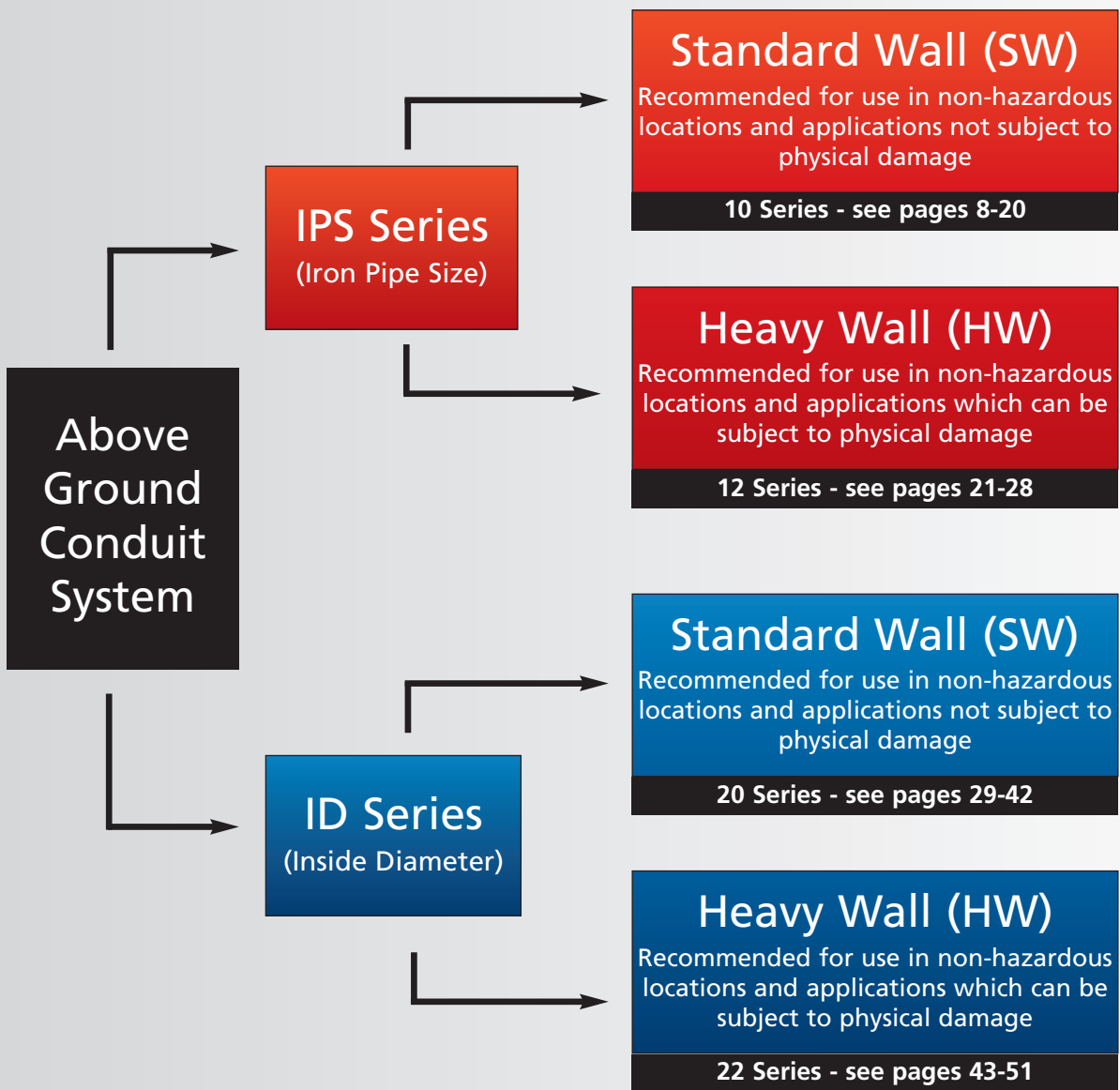

Upon special request, FRE Composites products can be designed to meet specific requirements such as wall thickness, offset elbows, special radii elbows and adapters.

TABLE OF CONTENTS

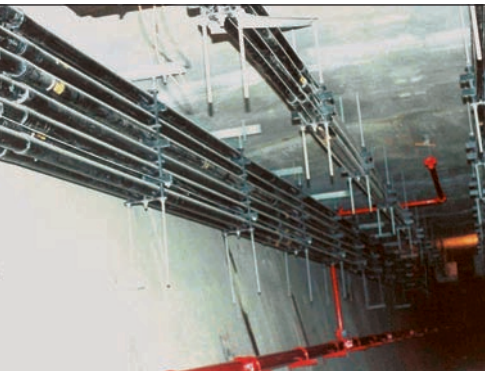

President's Message	3
---------------------	---

PRODUCT FEATURES

FRE® Above Ground Conduit System	4
Characteristics and applications	6-7

PRODUCT SPECIFICATIONS

IPS Standard Wall (SW) Conduit System	8-20
IPS Heavy Wall (HW) Conduit System	21-28
ID Standard Wall (SW) Conduit System	29-42
ID Heavy Wall (HW) Conduit System	43-51
IPS & ID Standard Wall (SW) Accessories	52
IPS & ID General Accessories	53-54
Product Test Data & Chemical Resistance	55
Representative Performance Specs & Flexural Data	56
Conduit Deflection Tables	57-59
Pulling Tension for Cables	60
Wire Fill	61
Glossary	62
Standard Conduit Packaging	63

LIMITATION OF LIABILITY

Due to the varied nature of electrical system designs, field conditions and installation techniques and practices under which FRE® Above Ground Conduit may be used, no guaranty or promise can be made regarding its performance in individual applications, since these factors are beyond the control of FRE Composites (2005) Inc. ("FRE Inc."). Therefore FRE Inc. or any of its affiliates and associates, accepts no responsibility for the performance of installed Above Ground Conduit systems.

At the written request of the engineer, architect, designer or contractor responsible for the design, installation practices or supervision, FRE Inc. may provide assistance or on-site advice based on past experience but only as a guide for successful installation. However said engineer, architect, designer and contractor shall remain solely responsible for ensuring the design, installation practices and supervision are adequate for the intended application. FRE Inc. shall not be liable in any way towards anyone by reason of such assistance or on-site advice.

In all cases, FRE Inc.'s only liability will be the replacement of conduit or fittings shown to be defective in workmanship or materials prior to installation. Under no circumstances shall FRE Inc. be liable for any claims, damages, losses (including a loss of opportunity, business or profit) or costs whether based on the fault or negligence (whether gross or not) of FRE Inc., on contractual, legal or statutory warranties, strict liability or otherwise except as expressly provided herein.

FRE® Above Ground Conduit is primarily designed for use in exposed environments. Should prolonged exposure be desired, please contact us for details on special ultraviolet protection techniques.

FRE Inc. has prepared this data as a guide only. Although FRE Inc. believes the information contained herein is accurate and reliable, this information shall not be construed as representation, warranty or guarantee, whether express or implied. FRE Inc. reserves the right to update products and /or data as necessary without notice.

Why should you consider using **F**iberglass **R**einforced **E**poxy conduit?

Fiberglass conduit offers many advantages over other commonly used conduit, such as steel and PVC, as listed below:

EASE OF ASSEMBLY:

Epoxy fiberglass conduit is easy to install, partly resulting from its light weight, which facilitates handling. Fitting sections together using the push-fit spigot and bell design further facilitates assembly. Alternatively, fiberglass conduit can be joined through the application of epoxy adhesive, but this is usually not necessary. Contractors report that joining by way of FRE® Conduit push-fit TriSeal™ connections results in considerable labour savings.

LIGHTWEIGHT:

Epoxy fiberglass conduit weighs considerably less than PVC or steel, resulting in cost savings through reduced handling time, reduced assembly time, reduced requirements for mechanized handling, reduced freight charges, reduced system weight, and lower costs of support. By way of example, 2" (53 mm) FRE® conduit weighs 34 pounds (15 kg) per 100 ft (30 m), compared with 71 (32 kg) to 100 pounds (45 kg) for an identical length of PVC conduit, or about 330 pounds (150 kg) for a conduit made of steel. One hundred ft. of 4" (103 mm) FRE® conduit weighs in at 76 pounds (34 kg), compared with 230 pounds (104 kg) (Schedule 40) to 286 pounds (130 kg) (Schedule 80) for PVC and almost 1 000 pounds (454 kg) for steel.

LOW COEFFICIENT OF FRICTION:

The coefficient of friction of epoxy fiberglass is lower than that of steel, and considerably lower than that of PVC. This means that electrical cables are easier to pull through, resulting in labour savings, less stress on cables, and reduces the number of costly manholes. As FRE®'s minimum resin content is higher than industry standards, FRE®'s coefficient of friction is the lowest and product longevity is the best in the industry.

TEMPERATURE RANGE:

FRE® Conduit can withstand a wide array of temperature ranging from -40°F to 230°F (-40°C to 110°C). Unlike PVC which is extremely brittle in cold temperature (+40°F) and malleable in heat, FRE® Conduit maintains its unique characteristics.

NO BURN-THROUGH:

Unlike rigid PVC, epoxy fiberglass bends and elbows have a strong resistance to being cavitated or pierced as a result of rope pull.

CABLE FUSION:

Fiberglass is an excellent insulator. Unlike fiberglass conduit, steel conduit will weld with cable, and PVC conduit may fuse or melt under electrical fault conditions.

FLEXIBLE AND IMPACT RESISTANT:

The flexibility of epoxy fiberglass conduit allows it to conform to mildly uneven surfaces. Epoxy fiberglass conduit has tended to survive the stresses of earthquakes better than PVC or steel.

CORROSION RESISTANT:

Epoxy fiberglass is not affected by the effects of water or most other chemicals. Contact the factory for further information, if specific information is required.

NON-TOXIC:

Unlike PVC, epoxy fiberglass is low halogen and does not release bromine or chlorine.

a complete system

Why should you specify **FRE**® conduit made by FRE Composites?

There are a number of reasons why FRE® conduit offers the industry the most for its money. Our **experience** and **quality record** speak for themselves. We live and breathe quality: quality is the number one priority to which everything else is subordinate. After nearly fifty years in the business, we know how to do things right, and we know how to ensure that we keep doing them right.

Our **total production capacity** is the largest in the industry enabling us to produce large volumes of product within tight delivery deadlines, and product is available from **stocking distributors** throughout Canada, the United States and elsewhere around the world.

TO ENSURE THAT YOUR PROJECT WILL BENEFIT FROM THE HIGHEST QUALITY CONDUIT PRODUCTS, SPECIFY FRE® CONDUIT:

KEY SPECIFICATION POINTS:

- Shall comply with the latest applicable UL / CSA / NEMA standards.
- Conduit shall bear UL Listing #E53373 and CSA Certification #028032S.
- Shall be manufactured from E or E-CR glass and epoxy resin with no fillers.
- Shall have a resin content of 32%, plus or minus 3%.
- All joints shall be inside tapered bell end and of even socket depth through out the raceway (conduits & fittings).
- Shall be equipped with one-piece injection molded TriSeal™ push-fit integral bell and spigot.
- Union made.
- Multiple locations to better serve your needs.

**For more information, please contact us
1 888 849-9909**



low cost



your right choice

IPS STANDARD WALL (SW) FOR TYPICAL EXPOSED APPLICATIONS

IPS STANDARD WALL (SW) CONDUIT

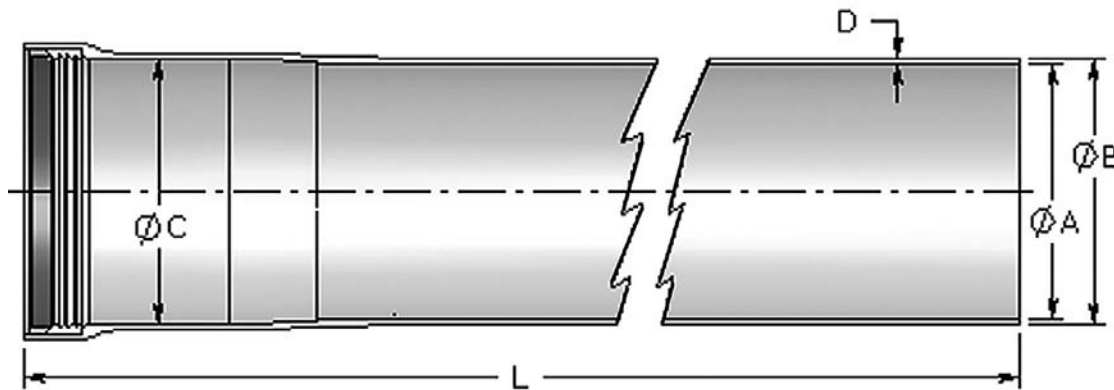

Size	Symbol	ØA	ØB	ØC	D	L	ØA	ØB	ØC	D	L	
in	mm	inches					millimeters					meters
¾	21	10-7500	0.918	1.050	1.086	0.066	118.25	23.3	26.7	27.6	1.7	3
1	27	10-1000	1.183	1.315	1.351	0.066	118.25	30.0	33.4	34.3	1.7	3
1¼	35	10-1200	1.528	1.660	1.698	0.066	118.25	38.8	42.2	43.1	1.7	3
1½	41	10-1500	1.768	1.900	1.938	0.066	118.25	44.9	48.3	49.2	1.7	3
2	53	10-2000	2.235	2.375	2.417	0.070	236.25	56.8	60.3	61.4	1.8	6
3	78	10-3000	3.360	3.500	3.542	0.070	236.25	85.3	88.9	90.0	1.8	6
4	103	10-4000	4.360	4.500	4.542	0.070	236.25	110.7	114.3	115.4	1.8	6
5	129	10-5000	5.373	5.563	5.610	0.095	236.25	136.5	141.3	142.5	2.4	6
6	155	10-6000	6.405	6.625	6.669	0.110	236.25	162.7	168.3	169.4	2.8	6
8❖	203	10-8000	8.395	8.625	8.667	0.115	236.25	213.2	219.1	220.1	2.9	6

- All our IPS Above Ground products are offered with a TriSeal™ for a push-fit assembly.
- Adhesives are available, if required.
- Standard length is 9.84 ft. (3m) for ¾" (19 mm) to 1½" (38 mm) and for 2" (51 mm) to 8" (203 mm) standard length is 19.68 ft. (6m) but can also be available in 9.84 ft. section (3m), if required.
- Spigot end tapered for ease of installation

❖ Not UL Listed, CSA Certified or NEMA compliant.



IPS SW DOUBLE BELL COUPLING

Size	Symbol	ØC	D	L	ØC	D	L	
in	mm	inches			millimeters			
¾	21	10-7510	1.086	0.066	9.750	27.6	1.7	247.7
1	27	10-1010	1.351	0.066	9.750	34.3	1.7	247.7
1¼	35	10-1210	1.698	0.066	9.750	43.1	1.7	247.7
1½	41	10-1510	1.938	0.066	9.750	49.2	1.7	247.7
2	53	10-2010	2.417	0.070	10.250	61.4	1.8	260.4
3	78	10-3010	3.542	0.070	10.250	90.0	1.8	260.4
4	103	10-4010	4.542	0.070	10.250	115.4	1.8	260.4
5	129	10-5010	5.610	0.095	10.250	142.5	2.4	260.4
6	155	10-6010	6.669	0.110	10.250	169.4	2.8	260.4
8❖	203	10-8010	8.667	0.115	10.250	220.1	2.9	260.4

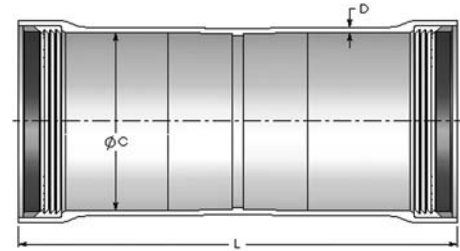

IPS SW 5° DOUBLE BELL COUPLING

Size	Symbol	ØC	D	L	ØC	D	L	
in	mm	inches			millimeters			
¾	21	10-7511	1.086	0.066	0.125	27.6	1.7	3.2
1	27	10-1011	1.351	0.066	0.125	34.3	1.7	3.2
1¼	35	10-1211	1.698	0.066	0.125	43.1	1.7	3.2
1½	41	10-1511	1.938	0.066	0.125	49.2	1.7	3.2
2	53	10-2011	2.417	0.070	0.125	61.4	1.8	3.2
3	78	10-3011	3.542	0.070	0.125	90.0	1.8	3.2
4	103	10-4011	4.542	0.070	0.125	115.4	1.8	3.2
5	129	10-5011	5.610	0.095	0.125	142.5	2.4	3.2
6	155	10-6011	6.669	0.110	0.125	169.4	2.8	3.2
8❖	203	10-8011	8.667	0.115	0.125	220.1	2.9	3.2

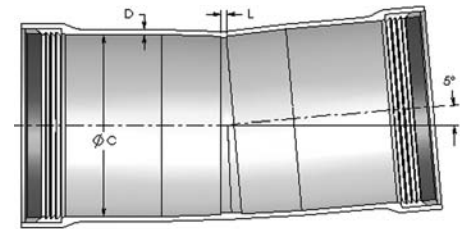

IPS SW SLEEVE

Size	Symbol	ØC	D	L	ØC	D	L	
in	mm	inches			millimeters			
¾	21	10-7516	1.086	0.066	12	27.6	1.7	304.8
1	27	10-1016	1.351	0.066	12	34.3	1.7	304.8
1¼	35	10-1216	1.698	0.066	12	43.1	1.7	304.8
1½	41	10-1516	1.938	0.066	12	49.2	1.7	304.8
2	53	10-2016	2.417	0.070	12	61.4	1.8	304.8
3	78	10-3016	3.542	0.070	12	90.0	1.8	304.8
4	103	10-4016	4.542	0.070	12	115.4	1.8	304.8
5	129	10-5016	5.610	0.095	12	142.5	2.4	304.8
6	155	10-6016	6.669	0.110	12	169.4	2.8	304.8
8❖	203	10-8016	8.667	0.115	12	220.1	2.9	304.8

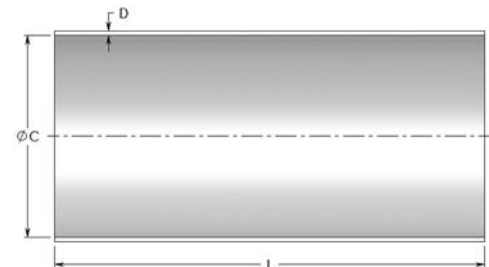

❖ Not UL Listed, CSA Certified or NEMA compliant.



IPS SW SINGLE EXPANSION JOINT

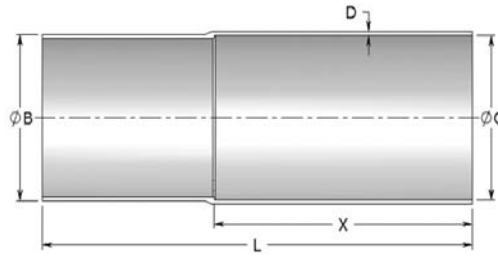

Size		Symbol No.	ØB	ØC	D	L	X	ØB	ØC	D	L	X
in	mm		inches					millimeters				
¾	21	10-7512	1.050	1.086	0.066	20	12	26.7	27.6	1.7	508.0	304.8
1	27	10-1012	1.315	1.351	0.066	20	12	33.4	34.3	1.7	508.0	304.8
1¼	35	10-1212	1.660	1.698	0.066	20	12	42.2	43.1	1.7	508.0	304.8
1½	41	10-1512	1.900	1.938	0.066	20	12	48.3	49.2	1.7	508.0	304.8
2	53	10-2012	2.375	2.417	0.070	20	12	60.3	61.4	1.8	508.0	304.8
3	78	10-3012	3.500	3.542	0.070	20	12	88.9	90.0	1.8	508.0	304.8
4	103	10-4012	4.500	4.542	0.070	20	12	114.3	115.4	1.8	508.0	304.8
5	129	10-5012	5.563	5.610	0.095	20	12	141.3	142.5	2.4	508.0	304.8
6	155	10-6012	6.625	6.669	0.110	20	12	168.3	169.4	2.8	508.0	304.8
8❖	203	10-8012	8.625	8.667	0.115	20	12	219.1	220.1	2.9	508.0	304.8

IPS SW O-RING EXPANSION JOINT

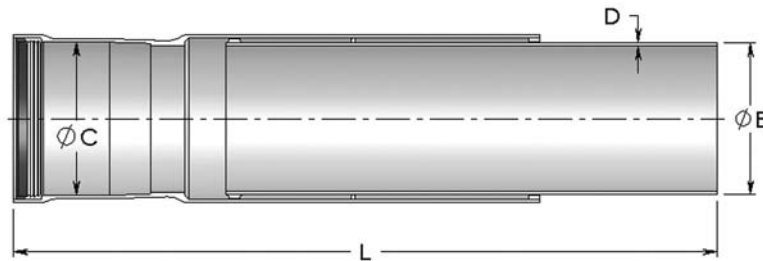

Size		Symbol No.	ØB	ØC	D	L min	L max	ØB	ØC	D	L min	L max
in	mm		inches					millimeters				
¾	21	10-7517	1.050	1.086	0.066	24	36	26.7	27.6	1.7	609.6	914.4
1	27	10-1017	1.315	1.351	0.066	24	36	33.4	34.3	1.7	609.6	914.4
1¼	35	10-1217	1.660	1.698	0.066	24	36	42.2	43.1	1.7	609.6	914.4
1½	41	10-1517	1.900	1.938	0.066	24	36	48.3	49.2	1.7	609.6	914.4
2	53	10-2017	2.375	2.417	0.070	24	36	60.3	61.4	1.8	609.6	914.4
3	78	10-3017	3.500	3.542	0.070	24	36	88.9	90.0	1.8	609.6	914.4
4	103	10-4017	4.500	4.542	0.070	24	36	114.3	115.4	1.8	609.6	914.4
5	129	10-5017	5.563	5.610	0.095	24	36	141.3	142.5	2.4	609.6	914.4
6	155	10-6017	6.625	6.669	0.110	24	36	168.3	169.4	2.8	609.6	914.4
8❖	203	10-8017	8.625	8.667	0.115	24	36	219.1	220.1	2.9	609.6	914.4

❖ Not UL Listed, CSA Certified or NEMA compliant.



IPS SW O-RING EXPANSION / DEFLECTION JOINT

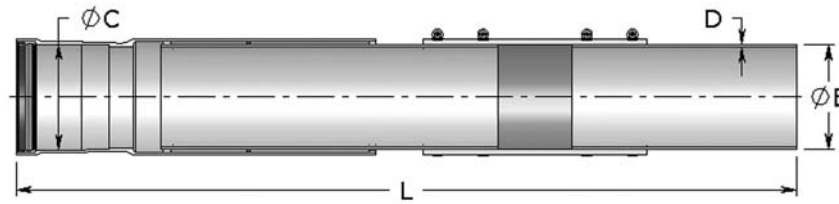

Size		Symbol No.	inches					millimeters				
in	mm		ØB	ØC	D	L min	L max	ØB	ØC	D	L min	L max
¾	21	10-7557	1.050	1.086	0.066	40	52	26.7	27.6	1.7	1016	1320.8
1	27	10-1057	1.315	1.351	0.066	40	52	33.4	34.3	1.7	1016	1320.8
1¼	35	10-1257	1.660	1.698	0.066	40	52	42.2	43.1	1.7	1016	1320.8
1½	41	10-1557	1.900	1.938	0.066	40	52	48.3	49.2	1.7	1016	1320.8
2	53	10-2057	2.375	2.417	0.070	40	52	60.3	61.4	1.8	1016	1320.8
3	78	10-3057	3.500	3.542	0.070	40	52	88.9	90.0	1.8	1016	1320.8
4	103	10-4057	4.500	4.542	0.070	40	52	114.3	115.4	1.8	1016	1320.8
5	129	10-5057	5.563	5.610	0.095	40	52	141.3	142.5	2.4	1016	1320.8
6	155	10-6057	6.625	6.669	0.110	40	52	168.3	169.4	2.8	1016	1320.8
8❖	203	10-8057	8.625	8.667	0.115	40	52	219.1	220.1	2.9	1016	1320.8

IPS SW WOBBLE (FOR UP TO 3° CURVATURE)

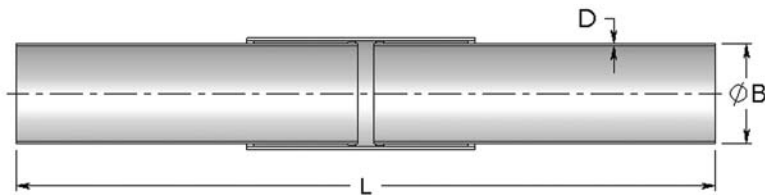

Size		Symbol No.	inches				millimeters			
in	mm		ØB	D	L min	L max	ØB	D	L min	L max
¾	21	10-7513	1.050	0.066	36	46	26.7	1.7	914.4	1168.4
1	27	10-1013	1.315	0.066	36	46	33.4	1.7	914.4	1168.4
1¼	35	10-1213	1.660	0.066	36	46	42.2	1.7	914.4	1168.4
1½	41	10-1513	1.900	0.066	36	46	48.3	1.7	914.4	1168.4
2	53	10-2013	2.375	0.070	36	46	60.3	1.8	914.4	1168.4
3	78	10-3013	3.500	0.070	36	46	88.9	1.8	914.4	1168.4
4	103	10-4013	4.500	0.070	36	46	114.3	1.8	914.4	1168.4
5	129	10-5013	5.563	0.095	36	46	141.3	2.4	914.4	1168.4
6	155	10-6013	6.625	0.110	36	46	168.3	2.8	914.4	1168.4
8❖	203	10-8013	8.625	0.115	36	46	219.1	2.9	914.4	1168.4

❖ Not UL Listed, CSA Certified or NEMA compliant.



IPS SW SKEW WOBBLE (FOR UP TO 7.5° CURVATURE)

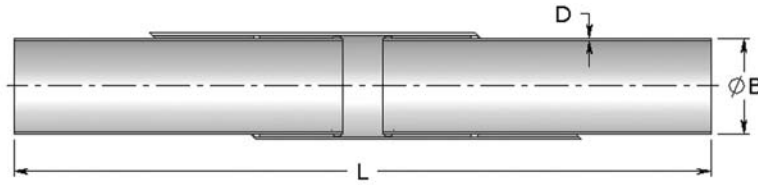

Size		Symbol	ØB	D	L min	L max	ØB	D	L min	L max
in	mm	No.	inches				millimeters			
¾	21	10-7514	1.050	0.066	48	56	26.7	1.7	1219.2	1422.4
1	27	10-1014	1.315	0.066	48	56	33.4	1.7	1219.2	1422.4
1¼	35	10-1214	1.660	0.066	48	56	42.2	1.7	1219.2	1422.4
1½	41	10-1514	1.900	0.066	48	56	48.3	1.7	1219.2	1422.4
2	53	10-2014	2.375	0.070	48	56	60.3	1.8	1219.2	1422.4
3	78	10-3014	3.500	0.070	48	56	88.9	1.8	1219.2	1422.4
4	103	10-4014	4.500	0.070	48	56	114.3	1.8	1219.2	1422.4
5	129	10-5014	5.563	0.095	48	56	141.3	2.4	1219.2	1422.4
6	155	10-6014	6.625	0.110	48	56	168.3	2.8	1219.2	1422.4
8❖	203	10-8014	8.625	0.115	48	56	219.1	2.9	1219.2	1422.4

IPS SW NPT FEMALE THREADED ADAPTER

Size		Symbol	ØC	D	L	X	ØC	D	L	X
in	mm	No.	inches				millimeters			
¾	21	10-7544	1.086	0.066	6.75	0.553	27.6	1.7	171.5	14.0
1	27	10-1044	1.351	0.066	6.75	0.661	34.3	1.7	171.5	16.8
1¼	35	10-1244	1.698	0.066	6.75	0.681	43.1	1.7	171.5	17.3
1½	41	10-1544	1.938	0.066	6.75	0.681	49.2	1.7	171.5	17.3
2	53	10-2044	2.417	0.070	8.00	0.697	61.4	1.8	203.2	17.7
3	78	10-3044	3.542	0.070	8.00	1.016	90.0	1.8	203.2	25.8
4	103	10-4044	4.542	0.070	8.00	1.094	115.4	1.8	203.2	27.8
5	129	10-5044	5.610	0.095	8.00	1.187	142.5	2.4	203.2	30.1
6	155	10-6044	6.669	0.110	8.00	1.208	169.4	2.8	203.2	30.7
8❖	203	10-8044	8.667	0.115	8.00	1.313	220.1	2.9	203.2	33.4

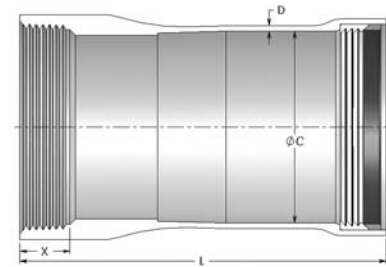

IPS SW NPT MALE THREADED ADAPTER

Size		Symbol	ØC	D	L	X	ØC	D	L	X
in	mm	No.	inches				millimeters			
¾	21	10-7527	1.086	0.066	6.75	0.546	27.6	1.7	171.5	13.9
1	27	10-1027	1.351	0.066	6.75	0.683	34.3	1.7	171.5	17.3
1¼	35	10-1227	1.698	0.066	6.75	0.707	43.1	1.7	171.5	18.0
1½	41	10-1527	1.938	0.066	6.75	0.724	49.2	1.7	171.5	18.4
2	53	10-2027	2.417	0.070	8.00	0.757	61.4	1.8	203.2	19.2
3	78	10-3027	3.542	0.070	8.00	1.200	90.0	1.8	203.2	30.5
4	103	10-4027	4.542	0.070	8.00	1.300	115.4	1.8	203.2	33.0
5	129	10-5027	5.610	0.095	8.00	1.406	142.5	2.4	203.2	35.7
6	155	10-6027	6.669	0.110	8.00	1.513	169.4	2.8	203.2	38.4
8❖	203	10-8027	8.667	0.115	8.00	1.713	220.1	2.9	203.2	43.5

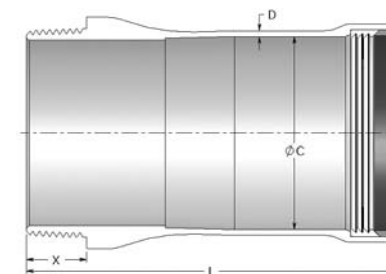

❖ Not UL Listed, CSA Certified or NEMA compliant.



IPS SW SPLIT STOP RING

Size		Symbol	ØC	D	L	ØC	D	L
in	mm	No.	inches			millimeters		
¾	21	10-7564	1.086	0.185	2	27.6	4.7	50.8
1	27	10-1064	1.351	0.185	2	34.3	4.7	50.8
1¼	35	10-1264	1.698	0.185	2	43.1	4.7	50.8
1½	41	10-1564	1.938	0.185	2	49.2	4.7	50.8
2	53	10-2064	2.417	0.185	2	61.4	4.7	50.8
3	78	10-3064	3.542	0.185	2	90.0	4.7	50.8
4	103	10-4064	4.542	0.185	2	115.4	4.7	50.8
5	129	10-5064	5.610	0.185	2	142.5	4.7	50.8
6	155	10-6064	6.669	0.185	2	169.4	2.8	50.8
8❖	203	10-8064	8.667	0.185	2	220.1	4.7	50.8

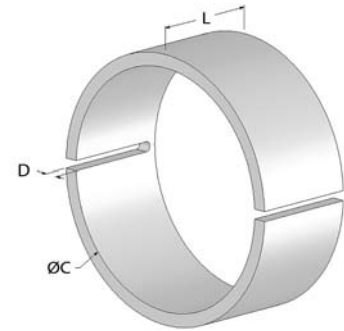

IPS SW REDUCER

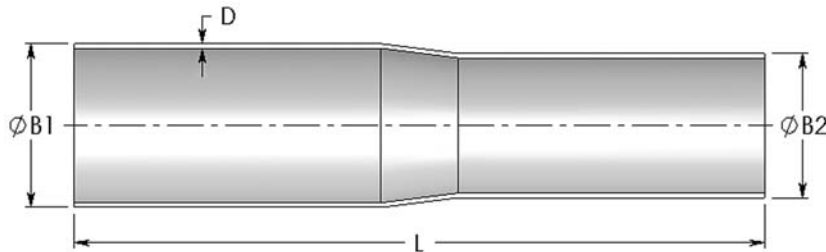

Size		Symbol	ØB1	ØB2	D	L	ØB1	ØB2	D	L
in	mm	No.	inches				millimeters			
1	27	10-1029	1.315	1.050	0.066	18	33.4	26.7	1.7	457.2
1¼	35	10-1229	1.660	1.315	0.066	18	42.2	33.4	1.7	457.2
1½	41	10-1529	1.900	1.660	0.066	18	48.3	42.2	1.7	457.2
2	53	10-2029	2.375	1.900	0.070	18	60.3	48.3	1.8	457.2
3	78	10-3029	3.500	2.375	0.070	18	88.9	60.3	1.8	457.2
4	103	10-4029	4.500	3.500	0.070	18	114.3	88.9	1.8	457.2
5	129	10-5029	5.563	4.500	0.095	18	141.3	114.3	2.4	457.2
6	155	10-6029	6.625	5.563	0.110	18	168.3	141.3	2.8	457.2

IPS SW 11.25° FITTING

Size		Symbol	ØB	ØC	D	L	ØB	ØC	D	L
in	mm	No.	inches				millimeters			
¾	21	10-7535	1.050	1.086	0.066	7	26.7	27.6	1.7	177.8
1	27	10-1035	1.315	1.351	0.066	7	33.4	34.3	1.7	177.8
1¼	35	10-1235	1.660	1.698	0.066	7	42.2	43.1	1.7	177.8
1½	41	10-1535	1.900	1.938	0.066	7	48.3	49.2	1.7	177.8
2	53	10-2035	2.375	2.417	0.070	7	60.3	61.4	1.8	177.8
3	78	10-3035	3.500	3.542	0.070	7	88.9	90.0	1.8	177.8
4	103	10-4035	4.500	4.542	0.070	7	114.3	115.4	1.8	177.8
5	129	10-5035	5.563	5.610	0.095	7	141.3	142.5	2.4	177.8
6	155	10-6035	6.625	6.669	0.110	7	168.3	169.4	2.8	177.8
8❖	203	10-8035	8.625	8.667	0.115	7	219.1	220.1	2.9	177.8

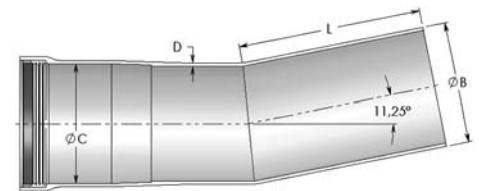

❖ Not UL Listed, CSA Certified or NEMA compliant.



IPS SW 11.25° ELBOW

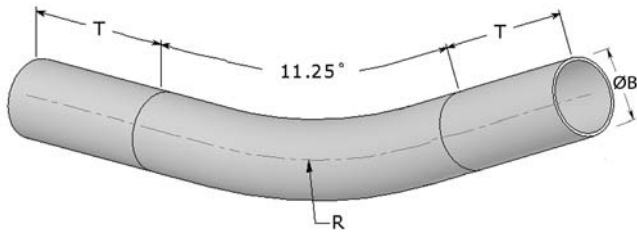

48" RADIUS

Size	Symbol	ØB R T			ØB R T			
		inches			millimeters			
in	mm	No.						
¾	21	10-7535R48	1.050	48	6	26.7	1219.2	152.4
1	27	10-1035R48	1.315	48	6	33.4	1219.2	152.4
1¼	35	10-1235R48	1.660	48	6	42.2	1219.2	152.4
1½	41	10-1535R48	1.900	48	6	48.3	1219.2	152.4
2	53	10-2035R48	2.375	48	6	60.3	1219.2	152.4
3	78	10-3035R48	3.500	48	6	88.9	1219.2	152.4
4	103	10-4035R48	4.500	48	6	114.3	1219.2	152.4
5	129	10-5035R48	5.563	48	6	141.3	1219.2	152.4
6	155	10-6035R48	6.625	48	6	168.3	1219.2	152.4

12" RADIUS

Size	Symbol	ØB R T			ØB R T			
		inches			millimeters			
in	mm	No.						
¾	21	10-7535R12	1.050	12	6	26.7	304.8	152.4
1	27	10-1035R12	1.315	12	6	33.4	304.8	152.4
1¼	35	10-1235R12	1.660	12	6	42.2	304.8	152.4
1½	41	10-1535R12	1.900	12	6	48.3	304.8	152.4
2	53	10-2035R12	2.375	12	6	60.3	304.8	152.4

60" RADIUS

Size	Symbol	ØB R T			ØB R T			
		inches			millimeters			
in	mm	No.						
¾	21	10-7535R60	1.050	60	6	26.7	1524.0	152.4
1	27	10-1035R60	1.315	60	6	33.4	1524.0	152.4
1¼	35	10-1235R60	1.660	60	6	42.2	1524.0	152.4
1½	41	10-1535R60	1.900	60	6	48.3	1524.0	152.4
2	53	10-2035R60	2.375	60	6	60.3	1524.0	152.4
3	78	10-3035R60	3.500	60	6	88.9	1524.0	152.4
4	103	10-4035R60	4.500	60	6	114.3	1524.0	152.4
5	129	10-5035R60	5.563	60	6	141.3	1524.0	152.4
6	155	10-6035R60	6.625	60	6	168.3	1524.0	152.4

24" RADIUS

Size	Symbol	ØB R T			ØB R T			
		inches			millimeters			
in	mm	No.						
¾	21	10-7535R24	1.050	24	6	26.7	609.6	152.4
1	27	10-1035R24	1.315	24	6	33.4	609.6	152.4
1¼	35	10-1235R24	1.660	24	6	42.2	609.6	152.4
1½	41	10-1535R24	1.900	24	6	48.3	609.6	152.4
2	53	10-2035R24	2.375	24	6	60.3	609.6	152.4
3	78	10-3035R24	3.500	24	6	88.9	609.6	152.4

72" RADIUS

Size	Symbol	ØB R T			ØB R T			
		inches			millimeters			
in	mm	No.						
¾	21	10-7535R72	1.050	72	6	26.7	1828.8	152.4
1	27	10-1035R72	1.315	72	6	33.4	1828.8	152.4
1¼	35	10-1235R72	1.660	72	6	42.2	1828.8	152.4
1½	41	10-1535R72	1.900	72	6	48.3	1828.8	152.4
2	53	10-2035R72	2.375	72	6	60.3	1828.8	152.4
3	78	10-3035R72	3.500	72	6	88.9	1828.8	152.4
4	103	10-4035R72	4.500	72	6	114.3	1828.8	152.4
5	129	10-5035R72	5.563	72	6	141.3	1828.8	152.4
6	155	10-6035R72	6.625	72	6	168.3	1828.8	152.4

36" RADIUS

Size	Symbol	ØB R T			ØB R T			
		inches			millimeters			
in	mm	No.						
¾	21	10-7535R36	1.050	36	6	26.7	914.4	152.4
1	27	10-1035R36	1.315	36	6	33.4	914.4	152.4
1¼	35	10-1235R36	1.660	36	6	42.2	914.4	152.4
1½	41	10-1535R36	1.900	36	6	48.3	914.4	152.4
2	53	10-2035R36	2.375	36	6	60.3	914.4	152.4
3	78	10-3035R36	3.500	36	6	88.9	914.4	152.4
4	103	10-4035R36	4.500	36	6	114.3	914.4	152.4

108" RADIUS

Size	Symbol	ØB R T			ØB R T			
		inches			millimeters			
in	mm	No.						
8❖	203	10-8035R108	8.625	108	6	219.1	2743.2	152.4

❖ Not UL Listed, CSA Certified or NEMA compliant.



IPS SW 22.5° ELBOW

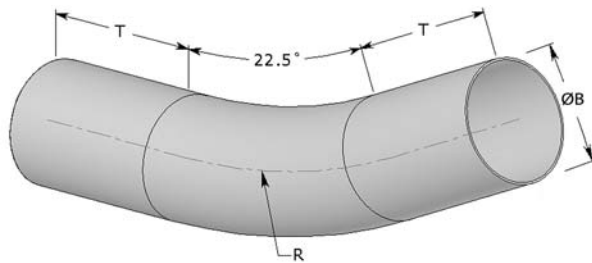

12" RADIUS

Size	Symbol	ØB	R	T	ØB	R	T	
in	mm	inches			millimeters			
¾	21	10-7534R12	1.050	12	6	26.7	304.8	152.4
1	27	10-1034R12	1.315	12	6	33.4	304.8	152.4
1¼	35	10-1234R12	1.660	12	6	42.2	304.8	152.4
1½	41	10-1534R12	1.900	12	6	48.3	304.8	152.4
2	53	10-2034R12	2.375	12	6	60.3	304.8	152.4

24" RADIUS

Size	Symbol	ØB	R	T	ØB	R	T	
in	mm	inches			millimeters			
¾	21	10-7534R24	1.050	24	6	26.7	609.6	152.4
1	27	10-1034R24	1.315	24	6	33.4	609.6	152.4
1¼	35	10-1234R24	1.660	24	6	42.2	609.6	152.4
1½	41	10-1534R24	1.900	24	6	48.3	609.6	152.4
2	53	10-2034R24	2.375	24	6	60.3	609.6	152.4
3	78	10-3034R24	3.500	24	6	88.9	609.6	152.4

36" RADIUS

Size	Symbol	ØB	R	T	ØB	R	T	
in	mm	inches			millimeters			
¾	21	10-7534R36	1.050	36	6	26.7	914.4	152.4
1	27	10-1034R36	1.315	36	6	33.4	914.4	152.4
1¼	35	10-1234R36	1.660	36	6	42.2	914.4	152.4
1½	41	10-1534R36	1.900	36	6	48.3	914.4	152.4
2	53	10-2034R36	2.375	36	6	60.3	914.4	152.4
3	78	10-3034R36	3.500	36	6	88.9	914.4	152.4
4	103	10-4034R36	4.500	36	6	114.3	914.4	152.4

48" RADIUS

Size	Symbol	ØB	R	T	ØB	R	T	
in	mm	inches			millimeters			
¾	21	10-7534R48	1.050	48	6	26.7	1219.2	152.4
1	27	10-1034R48	1.315	48	6	33.4	1219.2	152.4
1¼	35	10-1234R48	1.660	48	6	42.2	1219.2	152.4
1½	41	10-1534R48	1.900	48	6	48.3	1219.2	152.4
2	53	10-2034R48	2.375	48	6	60.3	1219.2	152.4
3	78	10-3034R48	3.500	48	6	88.9	1219.2	152.4
4	103	10-4034R48	4.500	48	6	114.3	1219.2	152.4
5	129	10-5034R48	5.563	48	6	141.3	1219.2	152.4
6	155	10-6034R48	6.625	48	6	168.3	1219.2	152.4

60" RADIUS

Size	Symbol	ØB	R	T	ØB	R	T	
in	mm	inches			millimeters			
¾	21	10-7534R60	1.050	60	6	26.7	1524.0	152.4
1	27	10-1034R60	1.315	60	6	33.4	1524.0	152.4
1¼	35	10-1234R60	1.660	60	6	42.2	1524.0	152.4
1½	41	10-1534R60	1.900	60	6	48.3	1524.0	152.4
2	53	10-2034R60	2.375	60	6	60.3	1524.0	152.4
3	78	10-3034R60	3.500	60	6	88.9	1524.0	152.4
4	103	10-4034R60	4.500	60	6	114.3	1524.0	152.4
5	129	10-5034R60	5.563	60	6	141.3	1524.0	152.4
6	155	10-6034R60	6.625	60	6	168.3	1524.0	152.4

72" RADIUS

Size	Symbol	ØB	R	T	ØB	R	T	
in	mm	inches			millimeters			
¾	21	10-7534R72	1.050	72	6	26.7	1828.8	152.4
1	27	10-1034R72	1.315	72	6	33.4	1828.8	152.4
1¼	35	10-1234R72	1.660	72	6	42.2	1828.8	152.4
1½	41	10-1534R72	1.900	72	6	48.3	1828.8	152.4
2	53	10-2034R72	2.375	72	6	60.3	1828.8	152.4
3	78	10-3034R72	3.500	72	6	88.9	1828.8	152.4
4	103	10-4034R72	4.500	72	6	114.3	1828.8	152.4
5	129	10-5034R72	5.563	72	6	141.3	1828.8	152.4
6	155	10-6034R72	6.625	72	6	168.3	1828.8	152.4

108" RADIUS

Size	Symbol	ØB	R	T	ØB	R	T	
in	mm	inches			millimeters			
8	203	10-8034R108	8.625	108	6	219.1	2743.2	152.4

❖ Not UL Listed, CSA Certified or NEMA compliant.



IPS SW 30° ELBOW

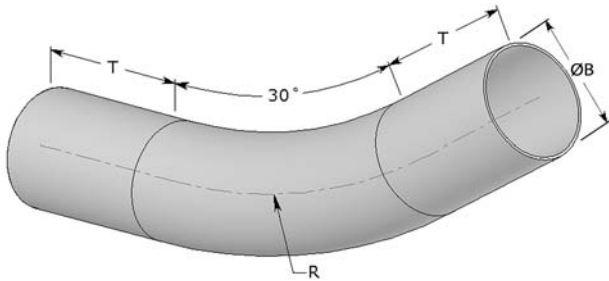

48" RADIUS

Size in mm	Symbol No.	inches			millimeters		
		ØB	R	T	ØB	R	T
¾	21 10-7533R48	1.050	48	6	26.7	1219.2	152.4
1	27 10-1033R48	1.315	48	6	33.4	1219.2	152.4
1¼	35 10-1233R48	1.660	48	6	42.2	1219.2	152.4
1½	41 10-1533R48	1.900	48	6	48.3	1219.2	152.4
2	53 10-2033R48	2.375	48	6	60.3	1219.2	152.4
3	78 10-3033R48	3.500	48	6	88.9	1219.2	152.4
4	103 10-4033R48	4.500	48	6	114.3	1219.2	152.4
5	129 10-5033R48	5.563	48	6	141.3	1219.2	152.4
6	155 10-6033R48	6.625	48	6	168.3	1219.2	152.4

12" RADIUS

Size in mm	Symbol No.	inches			millimeters		
		ØB	R	T	ØB	R	T
¾	21 10-7533R12	1.050	12	6	26.7	304.8	152.4
1	27 10-1033R12	1.315	12	6	33.4	304.8	152.4
1¼	35 10-1233R12	1.660	12	6	42.2	304.8	152.4
1½	41 10-1533R12	1.900	12	6	48.3	304.8	152.4
2	53 10-2033R12	2.375	12	6	60.3	304.8	152.4

60" RADIUS

Size in mm	Symbol No.	inches			millimeters		
		ØB	R	T	ØB	R	T
¾	21 10-7533R60	1.050	60	6	26.7	1524.0	152.4
1	27 10-1033R60	1.315	60	6	33.4	1524.0	152.4
1¼	35 10-1233R60	1.660	60	6	42.2	1524.0	152.4
1½	41 10-1533R60	1.900	60	6	48.3	1524.0	152.4
2	53 10-2033R60	2.375	60	6	60.3	1524.0	152.4
3	78 10-3033R60	3.500	60	6	88.9	1524.0	152.4
4	103 10-4033R60	4.500	60	6	114.3	1524.0	152.4
5	129 10-5033R60	5.563	60	6	141.3	1524.0	152.4
6	155 10-6033R60	6.625	60	6	168.3	1524.0	152.4

24" RADIUS

Size in mm	Symbol No.	inches			millimeters		
		ØB	R	T	ØB	R	T
¾	21 10-7533R24	1.050	24	6	26.7	609.6	152.4
1	27 10-1033R24	1.315	24	6	33.4	609.6	152.4
1¼	35 10-1233R24	1.660	24	6	42.2	609.6	152.4
1½	41 10-1533R24	1.900	24	6	48.3	609.6	152.4
2	53 10-2033R24	2.375	24	6	60.3	609.6	152.4
3	78 10-3033R24	3.500	24	6	88.9	609.6	152.4

72" RADIUS

Size in mm	Symbol No.	inches			millimeters		
		ØB	R	T	ØB	R	T
¾	21 10-7533R72	1.050	72	6	26.7	1828.8	152.4
1	27 10-1033R72	1.315	72	6	33.4	1828.8	152.4
1¼	35 10-1233R72	1.660	72	6	42.2	1828.8	152.4
1½	41 10-1533R72	1.900	72	6	48.3	1828.8	152.4
2	53 10-2033R72	2.375	72	6	60.3	1828.8	152.4
3	78 10-3033R72	3.500	72	6	88.9	1828.8	152.4
4	103 10-4033R72	4.500	72	6	114.3	1828.8	152.4
5	129 10-5033R72	5.563	72	6	141.3	1828.8	152.4
6	155 10-6033R72	6.625	72	6	168.3	1828.8	152.4

36" RADIUS

Size in mm	Symbol No.	inches			millimeters		
		ØB	R	T	ØB	R	T
¾	21 10-7533R36	1.050	36	6	26.7	914.4	152.4
1	27 10-1033R36	1.315	36	6	33.4	914.4	152.4
1¼	35 10-1233R36	1.660	36	6	42.2	914.4	152.4
1½	41 10-1533R36	1.900	36	6	48.3	914.4	152.4
2	53 10-2033R36	2.375	36	6	60.3	914.4	152.4
3	78 10-3033R36	3.500	36	6	88.9	914.4	152.4
4	103 10-4033R36	4.500	36	6	114.3	914.4	152.4

108" RADIUS

Size in mm	Symbol No.	inches			millimeters		
		ØB	R	T	ØB	R	T
8♦	203 10-8033R108	8.625	108	6	219.1	2743.2	152.4

♦ Not UL Listed, CSA Certified or NEMA compliant.



IPS SW 45° ELBOW

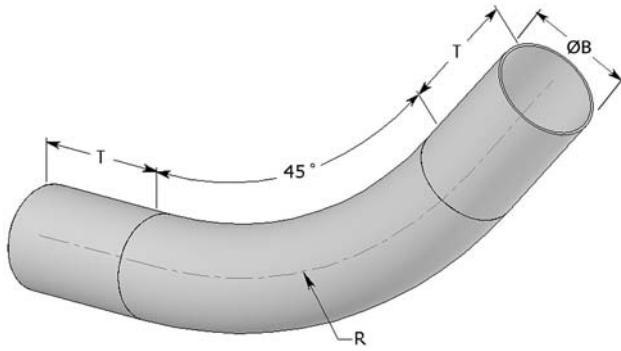

12" RADIUS

Size	Symbol	ØB	R	T	ØB	R	T	
in	mm	inches			millimeters			
¾	21	10-7532R12	1.050	12	6	26.7	304.8	152.4
1	27	10-1032R12	1.315	12	6	33.4	304.8	152.4
1¼	35	10-1232R12	1.660	12	6	42.2	304.8	152.4
1½	41	10-1532R12	1.900	12	6	48.3	304.8	152.4
2	53	10-2032R12	2.375	12	6	60.3	304.8	152.4

24" RADIUS

Size	Symbol	ØB	R	T	ØB	R	T	
in	mm	inches			millimeters			
¾	21	10-7532R24	1.050	24	6	26.7	609.6	152.4
1	27	10-1032R24	1.315	24	6	33.4	609.6	152.4
1¼	35	10-1232R24	1.660	24	6	42.2	609.6	152.4
1½	41	10-1532R24	1.900	24	6	48.3	609.6	152.4
2	53	10-2032R24	2.375	24	6	60.3	609.6	152.4
3	78	10-3032R24	3.500	24	6	88.9	609.6	152.4

36" RADIUS

Size	Symbol	ØB	R	T	ØB	R	T	
in	mm	inches			millimeters			
¾	21	10-7532R36	1.050	36	6	26.7	914.4	152.4
1	27	10-1032R36	1.315	36	6	33.4	914.4	152.4
1¼	35	10-1232R36	1.660	36	6	42.2	914.4	152.4
1½	41	10-1532R36	1.900	36	6	48.3	914.4	152.4
2	53	10-2032R36	2.375	36	6	60.3	914.4	152.4
3	78	10-3032R36	3.500	36	6	88.9	914.4	152.4
4	103	10-4032R36	4.500	36	6	114.3	914.4	152.4

48" RADIUS

Size	Symbol	ØB	R	T	ØB	R	T	
in	mm	inches			millimeters			
¾	21	10-7532R48	1.050	48	6	26.7	1219.2	152.4
1	27	10-1032R48	1.315	48	6	33.4	1219.2	152.4
1¼	35	10-1232R48	1.660	48	6	42.2	1219.2	152.4
1½	41	10-1532R48	1.900	48	6	48.3	1219.2	152.4
2	53	10-2032R48	2.375	48	6	60.3	1219.2	152.4
3	78	10-3032R48	3.500	48	6	88.9	1219.2	152.4
4	103	10-4032R48	4.500	48	6	114.3	1219.2	152.4
5	129	10-5032R48	5.563	48	6	141.3	1219.2	152.4
6	155	10-6032R48	6.625	48	6	168.3	1219.2	152.4

60" RADIUS

Size	Symbol	ØB	R	T	ØB	R	T	
in	mm	inches			millimeters			
¾	21	10-7532R60	1.050	60	6	26.7	1524.0	152.4
1	27	10-1032R60	1.315	60	6	33.4	1524.0	152.4
1¼	35	10-1232R60	1.660	60	6	42.2	1524.0	152.4
1½	41	10-1532R60	1.900	60	6	48.3	1524.0	152.4
2	53	10-2032R60	2.375	60	6	60.3	1524.0	152.4
3	78	10-3032R60	3.500	60	6	88.9	1524.0	152.4
4	103	10-4032R60	4.500	60	6	114.3	1524.0	152.4
5	129	10-5032R60	5.563	60	6	141.3	1524.0	152.4
6	155	10-6032R60	6.625	60	6	168.3	1524.0	152.4

72" RADIUS

Size	Symbol	ØB	R	T	ØB	R	T	
in	mm	inches			millimeters			
¾	21	10-7532R72	1.050	72	6	26.7	1828.8	152.4
1	27	10-1032R72	1.315	72	6	33.4	1828.8	152.4
1¼	35	10-1232R72	1.660	72	6	42.2	1828.8	152.4
1½	41	10-1532R72	1.900	72	6	48.3	1828.8	152.4
2	53	10-2032R72	2.375	72	6	60.3	1828.8	152.4
3	78	10-3032R72	3.500	72	6	88.9	1828.8	152.4
4	103	10-4032R72	4.500	72	6	114.3	1828.8	152.4
5	129	10-5032R72	5.563	72	6	141.3	1828.8	152.4
6	155	10-6032R72	6.625	72	6	168.3	1828.8	152.4

108" RADIUS

Size	Symbol	ØB	R	T	ØB	R	T	
in	mm	inches			millimeters			
8	203	10-8032R108	8.625	108	6	219.1	2743.2	152.4

❖ Not UL Listed, CSA Certified or NEMA compliant.



IPS SW 60° ELBOW

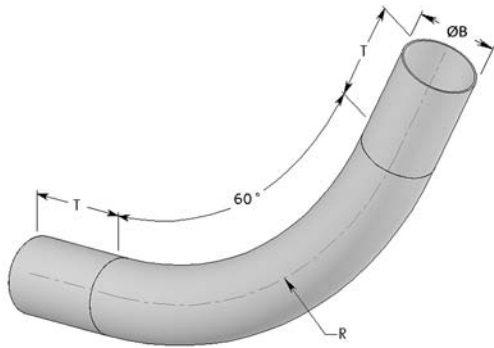

48" RADIUS

Size	Symbol	ØB	R	T	ØB	R	T	
in	mm	inches			millimeters			
	No.							
¾	21	10-7531R48	1.050	48	6	26.7	1219.2	152.4
1	27	10-1031R48	1.315	48	6	33.4	1219.2	152.4
1¼	35	10-1231R48	1.660	48	6	42.2	1219.2	152.4
1½	41	10-1531R48	1.900	48	6	48.3	1219.2	152.4
2	53	10-2031R48	2.375	48	6	60.3	1219.2	152.4
3	78	10-3031R48	3.500	48	6	88.9	1219.2	152.4
4	103	10-4031R48	4.500	48	6	114.3	1219.2	152.4
5	129	10-5031R48	5.563	48	6	141.3	1219.2	152.4
6	155	10-6031R48	6.625	48	6	168.3	1219.2	152.4

12" RADIUS

Size	Symbol	ØB	R	T	ØB	R	T	
in	mm	inches			millimeters			
	No.							
¾	21	10-7531R12	1.050	12	6	26.7	304.8	152.4
1	27	10-1031R12	1.315	12	6	33.4	304.8	152.4
1¼	35	10-1231R12	1.660	12	6	42.2	304.8	152.4
1½	41	10-1531R12	1.900	12	6	48.3	304.8	152.4

60" RADIUS

Size	Symbol	ØB	R	T	ØB	R	T	
in	mm	inches			millimeters			
	No.							
¾	21	10-7531R60	1.050	60	6	26.7	1524.0	152.4
1	27	10-1031R60	1.315	60	6	33.4	1524.0	152.4
1¼	35	10-1231R60	1.660	60	6	42.2	1524.0	152.4
1½	41	10-1531R60	1.900	60	6	48.3	1524.0	152.4
2	53	10-2031R60	2.375	60	6	60.3	1524.0	152.4
3	78	10-3031R60	3.500	60	6	88.9	1524.0	152.4
4	103	10-4031R60	4.500	60	6	114.3	1524.0	152.4
5	129	10-5031R60	5.563	60	6	141.3	1524.0	152.4
6	155	10-6031R60	6.625	60	6	168.3	1524.0	152.4

24" RADIUS

Size	Symbol	ØB	R	T	ØB	R	T	
in	mm	inches			millimeters			
	No.							
¾	21	10-7531R24	1.050	24	6	26.7	609.6	152.4
1	27	10-1031R24	1.315	24	6	33.4	609.6	152.4
1¼	35	10-1231R24	1.660	24	6	42.2	609.6	152.4
1½	41	10-1531R24	1.900	24	6	48.3	609.6	152.4
2	53	10-2031R24	2.375	24	6	60.3	609.6	152.4
3	78	10-3031R24	3.500	24	6	88.9	609.6	152.4

72" RADIUS

Size	Symbol	ØB	R	T	ØB	R	T	
in	mm	inches			millimeters			
	No.							
¾	21	10-7531R72	1.050	72	6	26.7	1828.8	152.4
1	27	10-1031R72	1.315	72	6	33.4	1828.8	152.4
1¼	35	10-1231R72	1.660	72	6	42.2	1828.8	152.4
1½	41	10-1531R72	1.900	72	6	48.3	1828.8	152.4
2	53	10-2031R72	2.375	72	6	60.3	1828.8	152.4
3	78	10-3031R72	3.500	72	6	88.9	1828.8	152.4
4	103	10-4031R72	4.500	72	6	114.3	1828.8	152.4
5	129	10-5031R72	5.563	72	6	141.3	1828.8	152.4
6	155	10-6031R72	6.625	72	6	168.3	1828.8	152.4

36" RADIUS

Size	Symbol	ØB	R	T	ØB	R	T	
in	mm	inches			millimeters			
	No.							
¾	21	10-7531R36	1.050	36	6	26.7	914.4	152.4
1	27	10-1031R36	1.315	36	6	33.4	914.4	152.4
1¼	35	10-1231R36	1.660	36	6	42.2	914.4	152.4
1½	41	10-1531R36	1.900	36	6	48.3	914.4	152.4
2	53	10-2031R36	2.375	36	6	60.3	914.4	152.4
3	78	10-3031R36	3.500	36	6	88.9	914.4	152.4
4	103	10-4031R36	4.500	36	6	114.3	914.4	152.4

108" RADIUS

Size	Symbol	ØB	R	T	ØB	R	T	
in	mm	inches			millimeters			
	No.							
8❖	203	10-8031R108	8.625	108	6	219.1	2743.2	152.4

❖ Not UL Listed, CSA Certified or NEMA compliant.



IPS SW 90° ELBOW

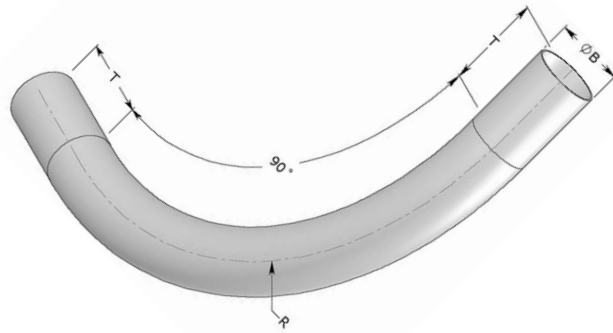

12" RADIUS

Size	Symbol	ØB	R	T	ØB	R	T	
in	mm	inches			millimeters			
¾	21	10-7530R12	1.050	12	6	26.7	304.8	152.4
1	27	10-1030R12	1.315	12	6	33.4	304.8	152.4
1¼	35	10-1230R12	1.660	12	6	42.2	304.8	152.4
1½	41	10-1530R12	1.900	12	6	48.3	304.8	152.4

18" RADIUS

Size	Symbol	ØB	R	T	ØB	R	T	
in	mm	inches			millimeters			
¾	21	10-7530R18	1.050	18	6	26.7	457.2	152.4
1	27	10-1030R18	1.315	18	6	33.4	457.2	152.4
1¼	35	10-1230R18	1.660	18	6	42.2	457.2	152.4
1½	41	10-1530R18	1.900	18	6	48.3	457.2	152.4
2	53	10-2030R18	2.375	18	6	60.3	457.2	152.4

24" RADIUS

Size	Symbol	ØB	R	T	ØB	R	T	
in	mm	inches			millimeters			
¾	21	10-7530R24	1.050	24	6	26.7	609.6	152.4
1	27	10-1030R24	1.315	24	6	33.4	609.6	152.4
1¼	35	10-1230R24	1.660	24	6	42.2	609.6	152.4
1½	41	10-1530R24	1.900	24	6	48.3	609.6	152.4
2	53	10-2030R24	2.375	24	6	60.3	609.6	152.4
3	78	10-3030R24	3.500	24	6	88.9	609.6	152.4

36" RADIUS

Size	Symbol	ØB	R	T	ØB	R	T	
in	mm	inches			millimeters			
¾	21	10-7530R36	1.050	36	6	26.7	914.4	152.4
1	27	10-1030R36	1.315	36	6	33.4	914.4	152.4
1¼	35	10-1230R36	1.660	36	6	42.2	914.4	152.4
1½	41	10-1530R36	1.900	36	6	48.3	914.4	152.4
2	53	10-2030R36	2.375	36	6	60.3	914.4	152.4
3	78	10-3030R36	3.500	36	6	88.9	914.4	152.4
4	103	10-4030R36	4.500	36	6	114.3	914.4	152.4
5	129	10-5030R36	5.563	36	6	141.3	914.4	152.4
6	155	10-6030R36	6.625	36	6	168.3	914.4	152.4

48" RADIUS

Size	Symbol	ØB	R	T	ØB	R	T	
in	mm	inches			millimeters			
¾	21	10-7530R48	1.050	48	6	26.7	1219.2	152.4
1	27	10-1030R48	1.315	48	6	33.4	1219.2	152.4
1¼	35	10-1230R48	1.660	48	6	42.2	1219.2	152.4
1½	41	10-1530R48	1.900	48	6	48.3	1219.2	152.4
2	53	10-2030R48	2.375	48	6	60.3	1219.2	152.4
3	78	10-3030R48	3.500	48	6	88.9	1219.2	152.4
4	103	10-4030R48	4.500	48	6	114.3	1219.2	152.4
5	129	10-5030R48	5.563	48	6	141.3	1219.2	152.4
6	155	10-6030R48	6.625	48	6	168.3	1219.2	152.4

60" RADIUS

Size	Symbol	ØB	R	T	ØB	R	T	
in	mm	inches			millimeters			
¾	21	10-7530R60	1.050	60	6	26.7	1524.0	152.4
1	27	10-1030R60	1.315	60	6	33.4	1524.0	152.4
1¼	35	10-1230R60	1.660	60	6	42.2	1524.0	152.4
1½	41	10-1530R60	1.900	60	6	48.3	1524.0	152.4
2	53	10-2030R60	2.375	60	6	60.3	1524.0	152.4
3	78	10-3030R60	3.500	60	6	88.9	1524.0	152.4
4	103	10-4030R60	4.500	60	6	114.3	1524.0	152.4
5	129	10-5030R60	5.563	60	6	141.3	1524.0	152.4
6	155	10-6030R60	6.625	60	6	168.3	1524.0	152.4

72" RADIUS

Size	Symbol	ØB	R	T	ØB	R	T	
in	mm	inches			millimeters			
2	53	10-2030R72	1.050	72	6	26.7	1828.8	152.4
3	78	10-3030R72	1.315	72	6	33.4	1828.8	152.4
4	103	10-4030R72	1.660	72	6	42.2	1828.8	152.4
5	129	10-5030R72	1.900	72	6	48.3	1828.8	152.4
6	155	10-6030R72	6.625	72	6	168.3	1828.8	152.4

108" RADIUS

Size	Symbol	ØB	R	T	ØB	R	T	
in	mm	inches			millimeters			
8	203	10-8030R108	8.625	108	6	219.1	2743.2	152.4



❖ Not UL Listed, CSA Certified or NEMA compliant.

IPS SW RISERWAY

Size	Symbol	$\varnothing B$	$\varnothing C$	D	L	$\varnothing B$	$\varnothing C$	D	L	
in	mm	inches			millimeters					
	No.									
2❖	53	10-2440	2.375	2.417	0.235	118	60.3	61.4	6.0	2997.2
3❖	78	10-3440	3.500	3.542	0.235	118	88.9	90.0	6.0	2997.2
4❖	103	10-4440	4.500	4.542	0.235	118	114.3	115.4	6.0	2997.2

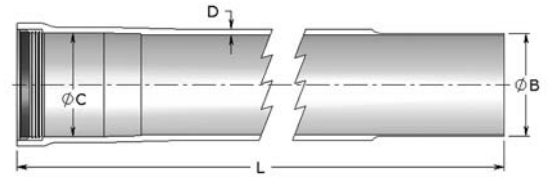

IPS SW OFFSET ELBOW

Size	Symbol
	No.
all	special

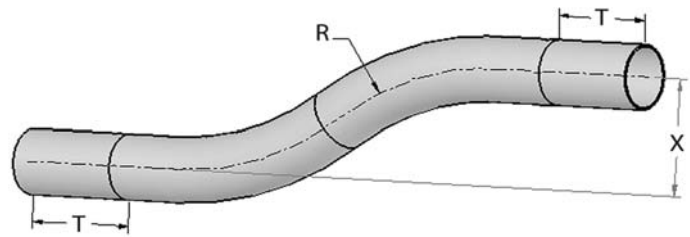

IPS SW CONDUIT BODIES

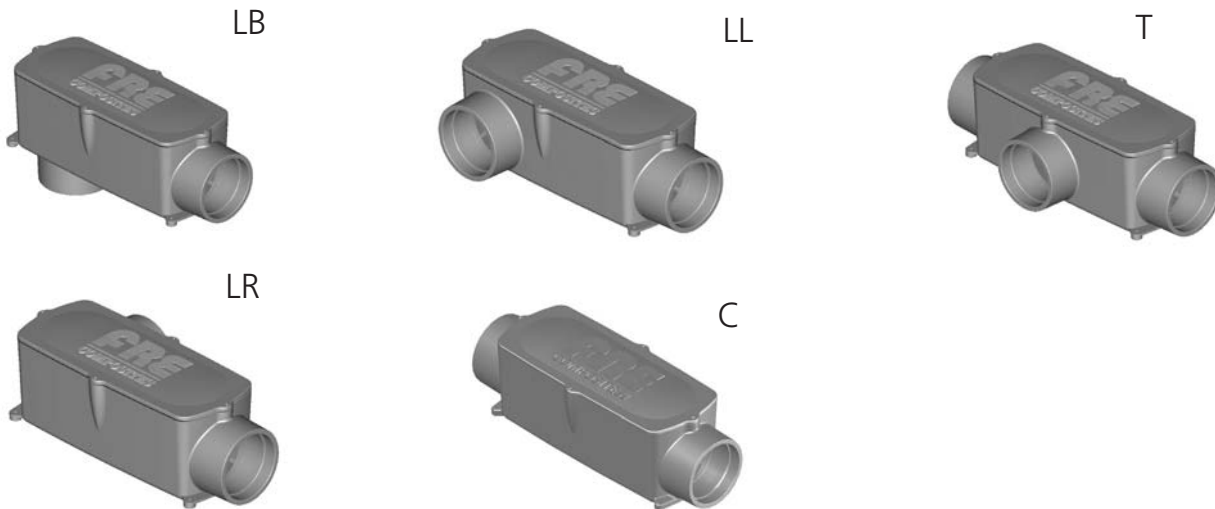

Size		Part number					Length	Width	Depth	Length	Width	Depth
in	mm	LB	LL	LR	T	C	inches			millimeters		
¾	21	10-7591	10-7592	10-7593	10-7594	10-7595	4.27	2.19	1.92	108	56	49
1	27	10-1091	10-1092	10-1093	10-1094	10-1095	5.19	2.44	2.22	132	62	56
1¼	35	10-1291	10-1292	10-1293	10-1294	10-1295	6.09	2.84	2.63	155	72	67
1½	41	10-1591	10-1592	10-1593	10-1594	10-1595	7.09	3.34	2.92	180	85	74
2	53	10-2091	10-2092	10-2093	10-2094	10-2095	8.75	3.88	3.34	222	99	85
3	78	10-3091	10-3092	10-3093	10-3094	10-3095	13.19	5.50	4.75	335	140	121
4*	103	10-4091	10-4092	10-4093	10-4094	10-4095	16.38	7.00	6.25	416	178	159

* Consult factory for availability

❖ Not UL Listed, CSA Certified or NEMA compliant.



IPS HEAVY WALL (HW) FOR ENHANCED MECHANICAL PROPERTIES

IPS HEAVY WALL (HW) CONDUIT

IPS
HW

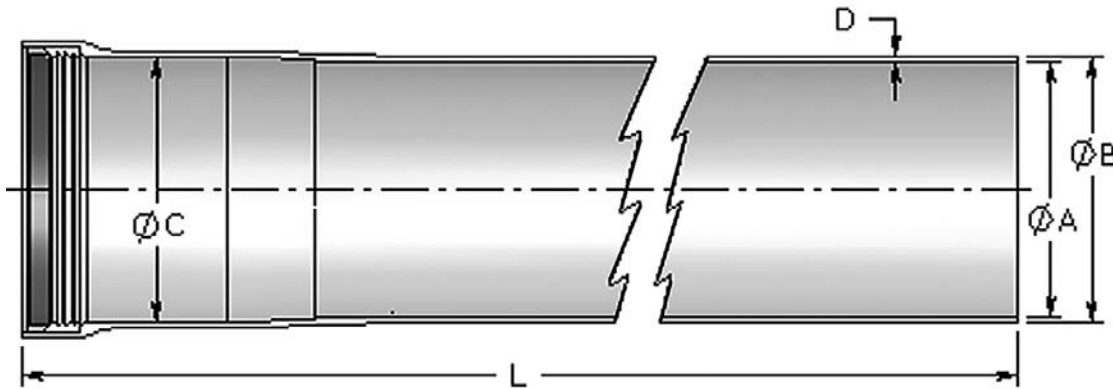

Size	Symbol	ØA	ØB	ØC	D	L	ØA	ØB	ØC	D	L	
in	mm	inches					millimeters				meters	
4	103	12-4000	4.360	4.550	4.590	0.095	236.25	110.7	115.6	116.6	2.4	6
5	129	12-5000	5.373	5.603	5.643	0.115	236.25	136.5	142.3	143.3	2.9	6
6	155	12-6000	6.405	6.635	6.675	0.115	236.25	162.7	168.5	169.5	2.9	6

- All our IPS Above Ground products are offered with a TriSeal™, for a push-fit assembly.
- Adhesives are available, if required.
- Standard length is 19.68 ft. (6m) but can also be available in 9.84 ft. section (3m), if required.
- Spigot end tapered for ease of installation.



IPS HW DOUBLE BELL COUPLING

Size		Symbol	ØC	D	L	ØC	D	L
in	mm	No.	inches			millimeters		
4	103	12-4010	4.590	0.095	10.250	116.6	2.4	260.4
5	129	12-5010	5.643	0.115	10.250	143.3	2.9	260.4
6	155	12-6010	6.675	0.115	10.250	169.5	2.9	260.4

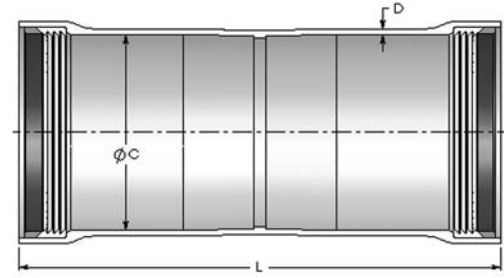

IPS HW

IPS HW 5° DOUBLE BELL COUPLING

Size		Symbol	ØC	D	L	ØC	D	L
in	mm	No.	inches			millimeters		
4	103	12-4011	4.590	0.095	0.125	116.6	2.4	3.2
5	129	12-5011	5.643	0.115	0.125	143.3	2.9	3.2
6	155	12-6011	6.675	0.115	0.125	169.5	2.9	3.2

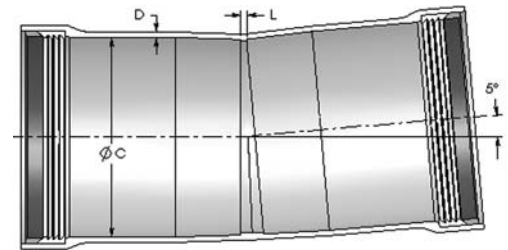

IPS HW SLEEVE

Size		Symbol	ØC	D	L	ØC	D	L
in	mm	No.	inches			millimeters		
4	103	12-4016	4.590	0.095	12	116.6	2.4	304.8
5	129	12-5016	5.643	0.115	12	143.3	2.9	304.8
6	155	12-6016	6.675	0.115	12	169.5	2.9	304.8

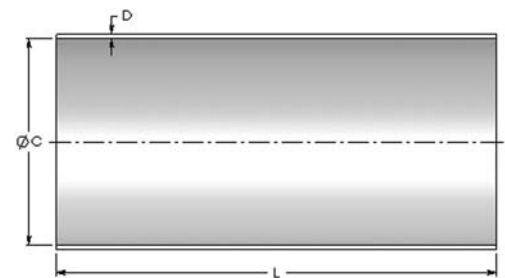

IPS HW SINGLE EXPANSION JOINT

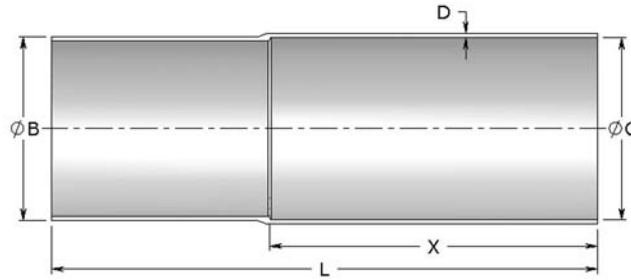

Size		Symbol	ØB	ØC	D	L	X	ØB	ØC	D	L	X
in	mm	No.	inches					millimeters				
4	103	12-4012	4.550	4.590	0.095	20	12	115.6	116.6	2.4	508.0	304.8
5	129	12-5012	5.603	5.643	0.115	20	12	142.3	143.3	2.9	508.0	304.8
6	155	12-6012	6.635	6.675	0.115	20	12	168.5	169.5	2.9	508.0	304.8

IPS HW O-RING EXPANSION JOINT

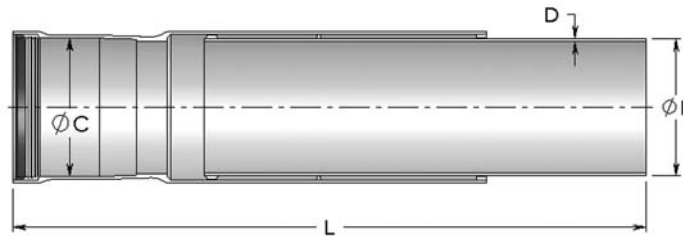

Size		Symbol	ØB	ØC	D	L min	L max	ØB	ØC	D	L min	L max
in	mm	No.	inches					millimeters				
4	103	12-4017	4.550	4.590	0.095	24	36	115.6	116.6	2.4	609.6	914.4
5	129	12-5017	5.603	5.643	0.115	24	36	142.3	143.3	2.9	609.6	914.4
6	155	12-6017	6.635	6.675	0.115	24	36	168.5	169.5	2.9	609.6	914.4

IPS HW O-RING EXPANSION / DEFLECTION JOINT

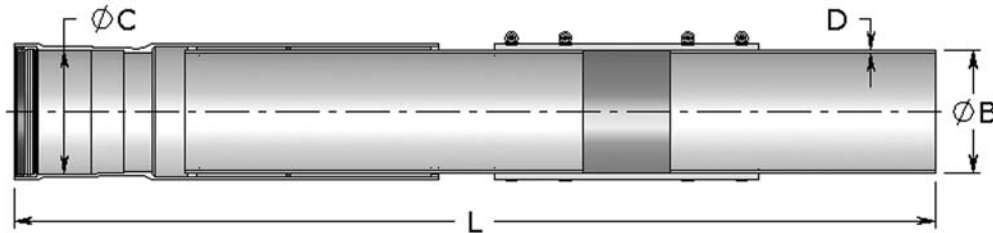

Size		Symbol	ØB	ØC	D	L min	L max	ØB	ØC	D	L min	L max
in	mm	No.	inches					millimeters				
4	103	12-4057	4.550	4.590	0.095	40	52	115.6	116.6	2.4	1016.0	1320.8
5	129	12-5057	5.603	5.643	0.115	40	52	142.3	143.3	2.9	1016.0	1320.8
6	155	12-6057	6.635	6.675	0.115	40	52	168.5	169.5	2.9	1016.0	1320.8

IPS
HW



IPS HW WOBBLE (FOR UP TO 3° CURVATURE)

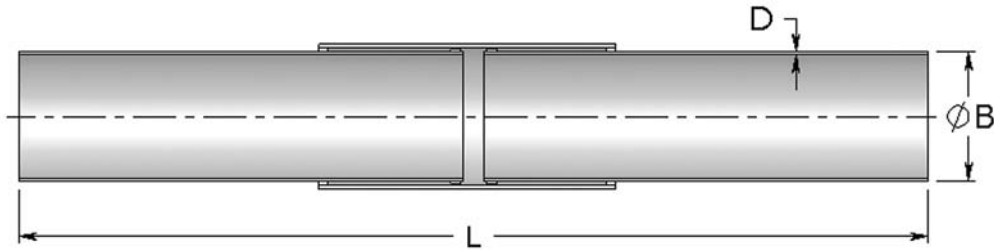

Size		Symbol No.	ØB	D	L min		L max			
in	mm				inches		millimeters			
4	103	12-4013	4.550	0.095	36	46	115.6	2.4	914.4	1168.4
5	129	12-5013	5.603	0.115	36	46	142.3	2.9	914.4	1168.4
6	155	12-6013	6.635	0.115	36	46	168.5	2.9	914.4	1168.4

IPS HW SKEW WOBBLE (FOR UP TO 7.5° CURVATURE)

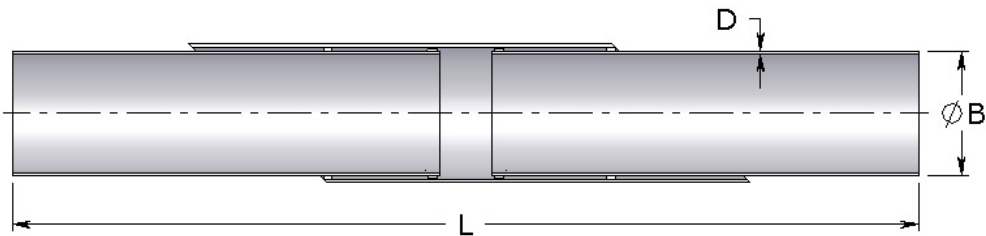

Size		Symbol No.	ØB	D	L min		L max			
in	mm				inches		millimeters			
4	103	12-4014	4.550	0.095	48	56	115.6	2.4	1219.2	1422.4
5	129	12-5014	5.603	0.115	48	56	142.3	2.9	1219.2	1422.4
6	155	12-6014	6.635	0.115	48	56	168.5	2.9	1219.2	1422.4

IPS HW

IPS HW NPT FEMALE THREADED ADAPTER

Size	Symbol	ØC	D	L	X	ØC	D	L	X	
in	mm	No.	inches			millimeters				
4	103	12-4044	4.590	0.095	8	1.094	116.6	2.4	203.2	27.8
5	129	12-5044	5.643	0.115	8	1.187	143.3	2.9	203.2	30.1
6	155	12-6044	6.675	0.115	8	1.208	169.5	2.9	203.2	30.7

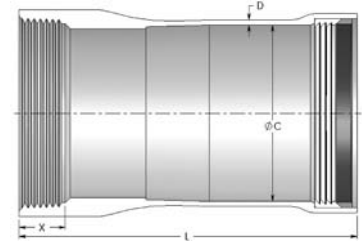

IPS HW NPT MALE THREADED ADAPTER

Size	Symbol	ØC	D	L	X	ØC	D	L	X	
in	mm	No.	inches			millimeters				
4	103	12-4027	4.590	0.095	8	1.300	116.6	2.4	203.2	33.0
5	129	12-5027	5.643	0.115	8	1.406	143.3	2.9	203.2	35.7
6	155	12-6027	6.675	0.115	8	1.513	169.5	2.9	203.2	38.4

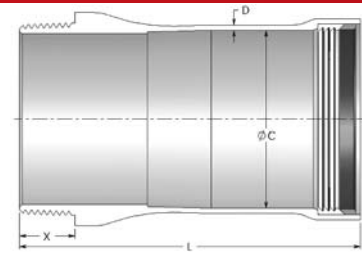

IPS HW SPLIT STOP RING

Size	Symbol	ØC	D	L	ØC	D	L	
in	mm	No.	inches		millimeters			
4	103	12-4064	4.590	0.185	2	116.6	4.7	50.8
5	129	12-5064	5.643	0.185	2	143.3	4.7	50.8
6	155	12-6064	6.675	0.185	2	169.5	4.7	50.8

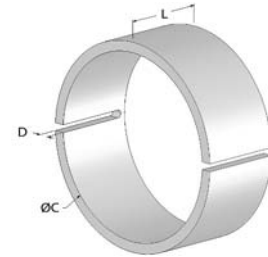

IPS HW REDUCER

Size	Symbol	ØB1	ØB2	D	L	ØB1	ØB2	D	L	
in	mm	No.	inches			millimeters				
4	103	12-4029	4.550	3.550	0.095	18	115.6	90.2	2.4	457.2
5	129	12-5029	5.603	4.550	0.115	18	142.3	115.6	2.9	457.2
6	155	12-6029	6.635	5.603	0.115	18	168.5	142.3	2.9	457.2

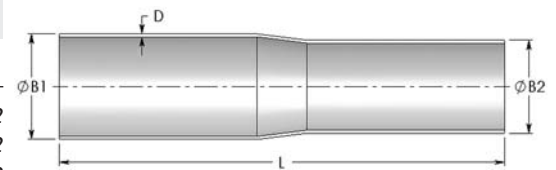

IPS HW 11.25° FITTING

Size	Symbol	ØB	ØC	D	L	ØB	ØC	D	L	
in	mm	No.	inches			millimeters				
4	103	12-4035	4.550	4.590	0.095	7	115.6	116.6	2.4	177.8
5	129	12-5035	5.603	5.643	0.115	7	142.3	143.3	2.9	177.8
6	155	12-6035	6.635	6.675	0.115	7	168.5	169.5	2.9	177.8

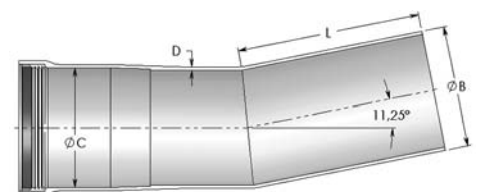

IPS HW 11.25° ELBOW

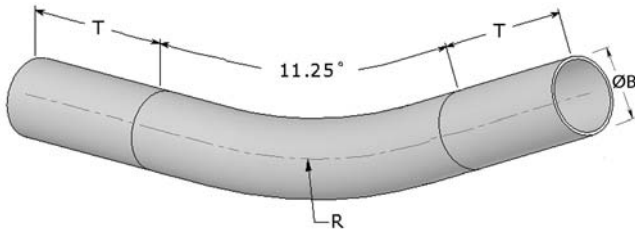

IPS HW 22.5° ELBOW

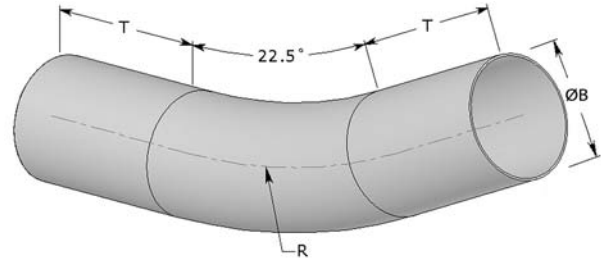

IPS HW

36" RADIUS

Size	Symbol	ØB	R	T	ØB	R	T	
in	mm	inches			millimeters			
	No.							
4	103	12-4035R36	4.550	36	6	115.6	914.4	152.4

36" RADIUS

Size	Symbol	ØB	R	T	ØB	R	T	
in	mm	inches			millimeters			
	No.							
4	103	12-4034R36	4.550	36	6	115.6	914.4	152.4
5	129	12-5034R36	5.603	36	6	142.3	914.4	152.4

48" RADIUS

Size	Symbol	ØB	R	T	ØB	R	T	
in	mm	inches			millimeters			
	No.							
4	103	12-4035R48	4.550	48	6	115.6	1219.2	152.4
5	129	12-5035R48	5.603	48	6	142.3	1219.2	152.4
6	155	12-6035R48	6.635	48	6	168.5	1219.2	152.4

48" RADIUS

Size	Symbol	ØB	R	T	ØB	R	T	
in	mm	inches			millimeters			
	No.							
4	103	12-4034R48	4.550	48	6	115.6	1219.2	152.4
5	129	12-5034R48	5.603	48	6	142.3	1219.2	152.4
6	155	12-6034R48	6.635	48	6	168.5	1219.2	152.4

60" RADIUS

Size	Symbol	ØB	R	T	ØB	R	T	
in	mm	inches			millimeters			
	No.							
4	103	12-4035R60	4.550	60	6	115.6	1524.0	152.4
5	129	12-5035R60	5.603	60	6	142.3	1524.0	152.4
6	155	12-6035R60	6.635	60	6	168.5	1524.0	152.4

60" RADIUS

Size	Symbol	ØB	R	T	ØB	R	T	
in	mm	inches			millimeters			
	No.							
4	103	12-4034R60	4.550	60	6	115.6	1524.0	152.4
5	129	12-5034R60	5.603	60	6	142.3	1524.0	152.4
6	155	12-6034R60	6.635	60	6	168.5	1524.0	152.4

72" RADIUS

Size	Symbol	ØB	R	T	ØB	R	T	
in	mm	inches			millimeters			
	No.							
4	103	12-4035R72	4.550	72	6	115.6	1828.8	152.4
5	129	12-5035R72	5.603	72	6	142.3	1828.8	152.4
6	155	12-6035R72	6.635	72	6	168.5	1828.8	152.4

72" RADIUS

Size	Symbol	ØB	R	T	ØB	R	T	
in	mm	inches			millimeters			
	No.							
4	103	12-4034R72	4.550	72	6	115.6	1828.8	152.4
5	129	12-5034R72	5.603	72	6	142.3	1828.8	152.4
6	155	12-6034R72	6.635	72	6	168.5	1828.8	152.4



IPS HW 30° ELBOW

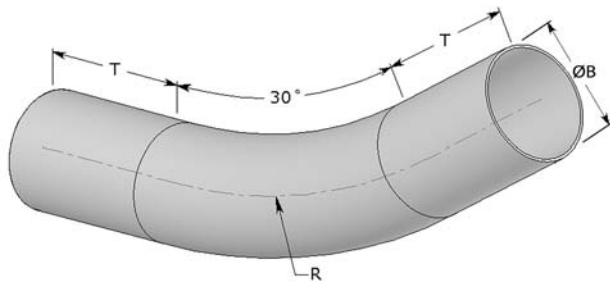

IPS HW 45° ELBOW

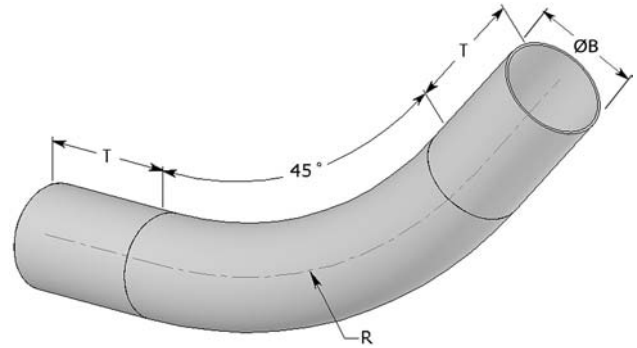

36" RADIUS

Size	Symbol	ØB	R	T	ØB	R	T	
in	mm	inches			millimeters			
	No.							
4	103	12-4033R36	4.550	36	6	115.6	914.4	152.4
5	129	12-5033R36	5.603	36	6	142.3	914.4	152.4

36" RADIUS

Size	Symbol	ØB	R	T	ØB	R	T	
in	mm	inches			millimeters			
	No.							
4	103	12-4032R36	4.550	36	6	115.6	914.4	152.4
5	129	12-5032R36	5.603	36	6	142.3	914.4	152.4

48" RADIUS

Size	Symbol	ØB	R	T	ØB	R	T	
in	mm	inches			millimeters			
	No.							
4	103	12-4033R48	4.550	48	6	115.6	1219.2	152.4
5	129	12-5033R48	5.603	48	6	142.3	1219.2	152.4
6	155	12-6033R48	6.635	48	6	168.5	1219.2	152.4

48" RADIUS

Size	Symbol	ØB	R	T	ØB	R	T	
in	mm	inches			millimeters			
	No.							
4	103	12-4032R48	4.550	48	6	115.6	1219.2	152.4
5	129	12-5032R48	5.603	48	6	142.3	1219.2	152.4
6	155	12-6032R48	6.635	48	6	168.5	1219.2	152.4

60" RADIUS

Size	Symbol	ØB	R	T	ØB	R	T	
in	mm	inches			millimeters			
	No.							
4	103	12-4033R60	4.550	60	6	115.6	1524.0	152.4
5	129	12-5033R60	5.603	60	6	142.3	1524.0	152.4
6	155	12-6033R60	6.635	60	6	168.5	1524.0	152.4

60" RADIUS

Size	Symbol	ØB	R	T	ØB	R	T	
in	mm	inches			millimeters			
	No.							
4	103	12-4032R60	4.550	60	6	115.6	1524.0	152.4
5	129	12-5032R60	5.603	60	6	142.3	1524.0	152.4
6	155	12-6032R60	6.635	60	6	168.5	1524.0	152.4

72" RADIUS

Size	Symbol	ØB	R	T	ØB	R	T	
in	mm	inches			millimeters			
	No.							
4	103	12-4033R72	4.550	72	6	115.6	1828.8	152.4
5	129	12-5033R72	5.603	72	6	142.3	1828.8	152.4
6	155	12-6033R72	6.635	72	6	168.5	1828.8	152.4

72" RADIUS

Size	Symbol	ØB	R	T	ØB	R	T	
in	mm	inches			millimeters			
	No.							
4	103	12-4032R72	4.550	72	6	115.6	1828.8	152.4
5	129	12-5032R72	5.603	72	6	142.3	1828.8	152.4
6	155	12-6032R72	6.635	72	6	168.5	1828.8	152.4

IPS
HW



IPS HW 60° ELBOW

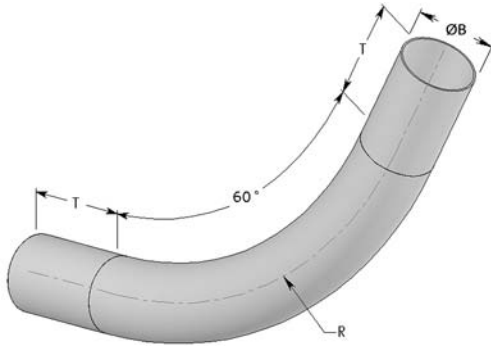

IPS HW 90° ELBOW

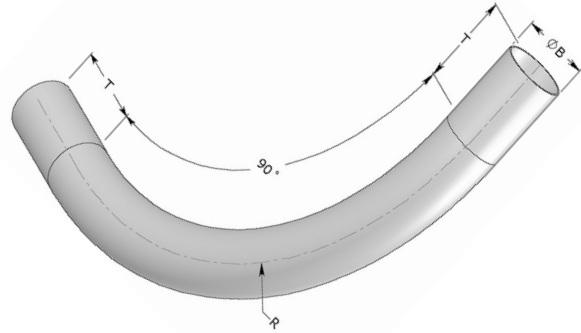

IPS HW

36" RADIUS

Size	Symbol	ØB	R	T	ØB	R	T
in	mm	inches			millimeters		
4	103	12-4031R36	4.550	36	6	115.6	914.4 152.4
5	129	12-5031R36	5.603	36	6	142.3	914.4 152.4

36" RADIUS

Size	Symbol	ØB	R	T	ØB	R	T
in	mm	inches			millimeters		
4	103	12-4030R36	4.550	36	6	115.6	914.4 152.4

48" RADIUS

Size	Symbol	ØB	R	T	ØB	R	T
in	mm	inches			millimeters		
4	103	12-4031R48	4.550	48	6	115.6	1219.2 152.4
5	129	12-5031R48	5.603	48	6	142.3	1219.2 152.4
6	155	12-6031R48	6.635	48	6	168.5	1219.2 152.4

48" RADIUS

Size	Symbol	ØB	R	T	ØB	R	T
in	mm	inches			millimeters		
4	103	12-4030R48	4.550	48	6	115.6	1219.2 152.4
5	129	12-5030R48	5.603	48	6	142.3	1219.2 152.4
6	155	12-6030R48	6.635	48	6	168.5	1219.2 152.4

60" RADIUS

Size	Symbol	ØB	R	T	ØB	R	T
in	mm	inches			millimeters		
4	103	12-4031R60	4.550	60	6	115.6	1524.0 152.4
5	129	12-5031R60	5.603	60	6	142.3	1524.0 152.4
6	155	12-6031R60	6.635	60	6	168.5	1524.0 152.4

60" RADIUS

Size	Symbol	ØB	R	T	ØB	R	T
in	mm	inches			millimeters		
4	103	12-4030R60	4.550	60	6	115.6	1524.0 152.4
5	129	12-5030R60	5.603	60	6	142.3	1524.0 152.4
6	155	12-6030R60	6.635	60	6	168.5	1524.0 152.4

72" RADIUS

Size	Symbol	ØB	R	T	ØB	R	T
in	mm	inches			millimeters		
4	103	12-4031R72	4.550	72	6	115.6	1828.8 152.4
5	129	12-5031R72	5.603	72	6	142.3	1828.8 152.4
6	155	12-6031R72	6.635	72	6	168.5	1828.8 152.4

72" RADIUS

Size	Symbol	ØB	R	T	ØB	R	T
in	mm	inches			millimeters		
4	103	12-4030R72	4.550	72	6	115.6	1828.8 152.4
5	129	12-5030R72	5.603	72	6	142.3	1828.8 152.4
6	155	12-6030R72	6.635	72	6	168.5	1828.8 152.4



ID STANDARD WALL (SW) FOR TYPICAL EXPOSED APPLICATIONS

ID STANDARD WALL (SW) CONDUIT

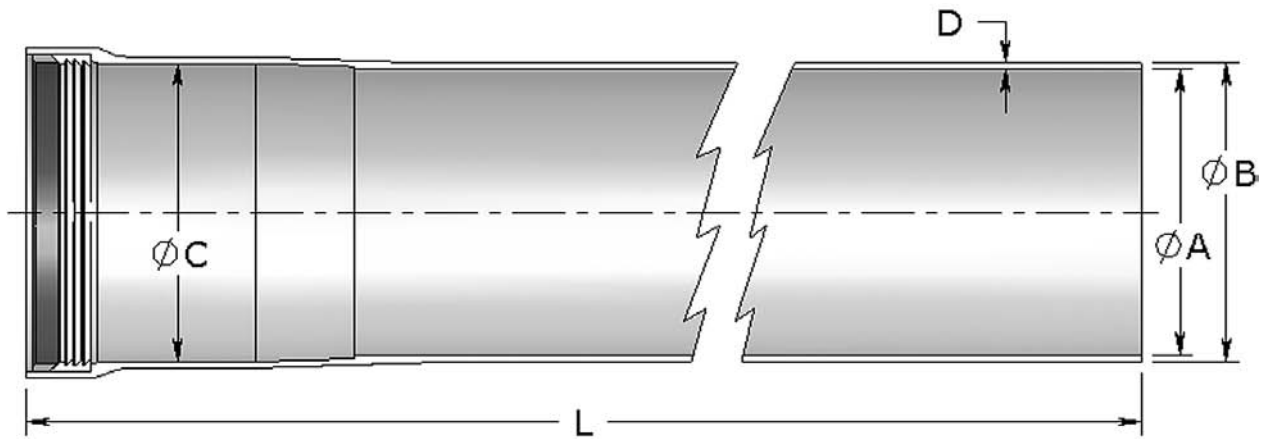

Size		Symbol No.	inches					millimeters				
in	mm		ØA	ØB	ØC	D	L	ØA	ØB	ØC	D	L
2	53	20-2000	2.000	2.140	2.170	0.070	236.25	50.8	54.4	55.1	1.8	6
2½	63	20-2500	2.500	2.640	2.670	0.070	236.25	63.5	67.1	67.8	1.8	6
3	78	20-3000	3.000	3.140	3.170	0.070	236.25	76.2	79.8	80.5	1.8	6
3½	91	20-3500	3.500	3.640	3.670	0.070	236.25	88.9	92.5	93.2	1.8	6
4	103	20-4000	4.000	4.140	4.170	0.070	236.25	101.6	105.2	105.9	1.8	6
4½	116	20-4500	4.500	4.690	4.730	0.095	236.25	114.3	119.1	120.1	2.4	6
5	129	20-5000	5.000	5.190	5.230	0.095	236.25	127.0	131.8	132.8	2.4	6
6	155	20-6000	6.000	6.190	6.230	0.095	236.25	152.4	157.2	158.2	2.4	6

- All our ID Above Ground products are offered with a TriSeal™ for a push-fit assembly.
- Adhesives are available, if required.
- Standard length is 19.68 ft. (6m) but can also be available in 9.84 ft. section (3m), if required.
- Spigot end tapered for ease of installation



ID SW DOUBLE BELL COUPLING

Size	Symbol	$\varnothing C$	D	L	$\varnothing C$	D	L	
in	mm	inches			millimeters			
2	53	20-2010	2.170	0.070	10.25	55.1	1.8	260.4
2½	63	20-2510	2.670	0.070	10.25	67.8	1.8	260.4
3	78	20-3010	3.170	0.070	10.25	80.5	1.8	260.4
3½	91	20-3510	3.670	0.070	10.25	93.2	1.8	260.4
4	103	20-4010	4.170	0.070	10.25	105.9	1.8	260.4
4½	116	20-4510	4.730	0.095	10.25	120.1	2.4	260.4
5	129	20-5010	5.230	0.095	10.25	132.8	2.4	260.4
6	155	20-6010	6.230	0.095	10.25	158.2	2.4	260.4

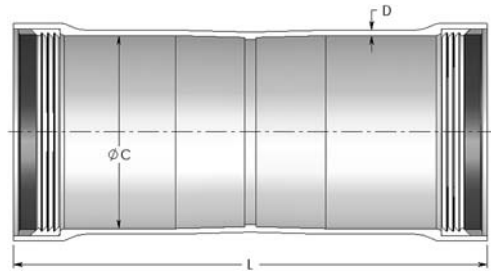

ID SW 5° DOUBLE BELL COUPLING

Size	Symbol	$\varnothing C$	D	L	$\varnothing C$	D	L	
in	mm	inches			millimeters			
2	53	20-2011	2.170	0.070	0.125	55.1	1.8	3.2
2½	63	20-2511	2.670	0.070	0.125	67.8	1.8	3.2
3	78	20-3011	3.170	0.070	0.125	80.5	1.8	3.2
3½	91	20-3511	3.670	0.070	0.125	93.2	1.8	3.2
4	103	20-4011	4.170	0.070	0.125	105.9	1.8	3.2
4½	116	20-4511	4.730	0.095	0.125	120.1	2.4	3.2
5	129	20-5011	5.230	0.095	0.125	132.8	2.4	3.2
6	155	20-6011	6.230	0.095	0.125	158.2	2.4	3.2

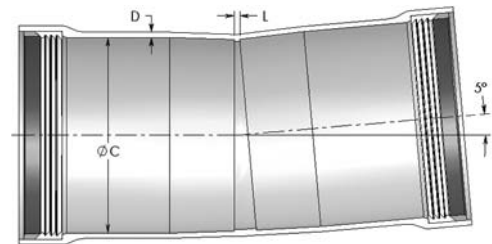

ID SW SLEEVE

Size	Symbol	$\varnothing C$	D	L	$\varnothing C$	D	L	
in	mm	inches			millimeters			
2	53	20-2016	2.170	0.070	12	55.1	1.8	304.8
2½	63	20-2516	2.670	0.070	12	67.8	1.8	304.8
3	78	20-3016	3.170	0.070	12	80.5	1.8	304.8
3½	91	20-3516	3.670	0.070	12	93.2	1.8	304.8
4	103	20-4016	4.170	0.070	12	105.9	1.8	304.8
4½	116	20-4516	4.730	0.095	12	120.1	2.4	304.8
5	129	20-5016	5.230	0.095	12	132.8	2.4	304.8
6	155	20-6016	6.230	0.095	12	158.2	2.4	304.8

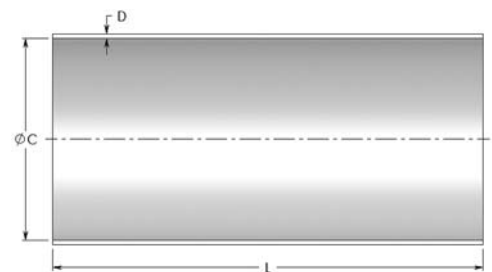

ID SW



ID SW SINGLE EXPANSION JOINT

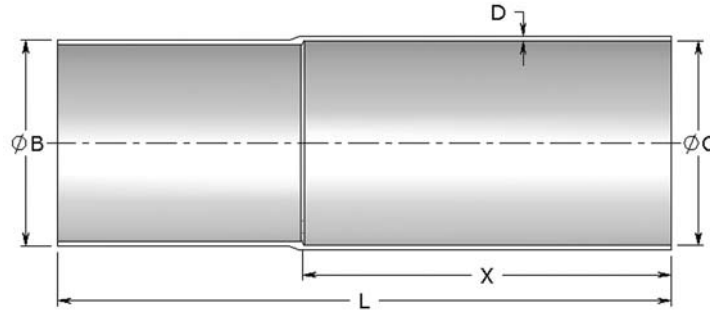

Size	Symbol	No.	inches					millimeters				
			ØB	ØC	D	L	X	ØB	ØC	D	L	X
2	53	20-2012	2.140	2.170	0.070	20	12	54.4	55.1	1.8	508.0	304.8
2½	63	20-2512	2.640	2.670	0.070	20	12	67.1	67.8	1.8	508.0	304.8
3	78	20-3012	3.140	3.170	0.070	20	12	79.8	80.5	1.8	508.0	304.8
3½	91	20-3512	3.640	3.670	0.070	20	12	92.5	93.2	1.8	508.0	304.8
4	103	20-4012	4.140	4.170	0.070	20	12	105.2	105.9	1.8	508.0	304.8
4½	116	20-4512	4.690	4.730	0.095	20	12	119.1	120.1	2.4	508.0	304.8
5	129	20-5012	5.190	5.230	0.095	20	12	131.8	132.8	2.4	508.0	304.8
6	155	20-6012	6.190	6.230	0.095	20	12	157.2	158.2	2.4	508.0	304.8

ID SW O-RING EXPANSION JOINT



Size	Symbol	No.	inches					millimeters				
			ØB	ØC	D	L min	L max	ØB	ØC	D	L min	L max
2	53	20-2017	2.140	2.170	0.070	24	36	54.4	55.1	1.8	609.6	914.4
2½	63	20-2517	2.640	2.670	0.070	24	36	67.1	67.8	1.8	609.6	914.4
3	78	20-3017	3.140	3.170	0.070	24	36	79.8	80.5	1.8	609.6	914.4
3½	91	20-3517	3.640	3.670	0.070	24	36	92.5	93.2	1.8	609.6	914.4
4	103	20-4017	4.140	4.170	0.070	24	36	105.2	105.9	1.8	609.6	914.4
4½	116	20-4517	4.690	4.730	0.095	24	36	119.1	120.1	2.4	609.6	914.4
5	129	20-5017	5.190	5.230	0.095	24	36	131.8	132.8	2.4	609.6	914.4
6	155	20-6017	6.190	6.230	0.095	24	36	157.2	158.2	2.4	609.6	914.4

ID SW O-RING EXPANSION / DEFLECTION JOINT

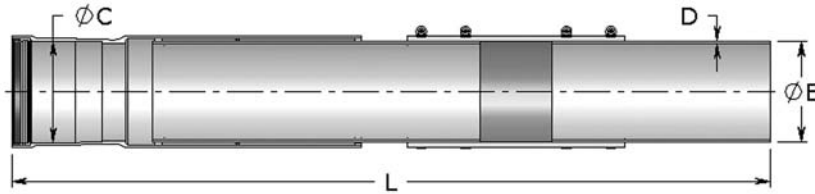

Size		Symbol	ØB	ØC	D	L min	L max	ØB	ØC	D	L min	L max
in	mm	No.	inches				millimeters					
2	53	20-2057	2.140	2.170	0.070	40	52	54.4	55.1	1.8	1016.0	1320.8
2½	63	20-2557	2.640	2.670	0.070	40	52	67.1	67.8	1.8	1016.0	1320.8
3	78	20-3057	3.140	3.170	0.070	40	52	79.8	80.5	1.8	1016.0	1320.8
3½	91	20-3557	3.640	3.670	0.070	40	52	92.5	93.2	1.8	1016.0	1320.8
4	103	20-4057	4.140	4.170	0.070	40	52	105.2	105.9	1.8	1016.0	1320.8
4½	116	20-4557	4.690	4.730	0.095	40	52	119.1	120.1	2.4	1016.0	1320.8
5	129	20-5057	5.190	5.230	0.095	40	52	131.8	132.8	2.4	1016.0	1320.8
6	155	20-6057	6.190	6.230	0.095	40	52	157.2	158.2	2.4	1016.0	1320.8

ID SW WOBBLE (FOR UP TO 3° CURVATURE)

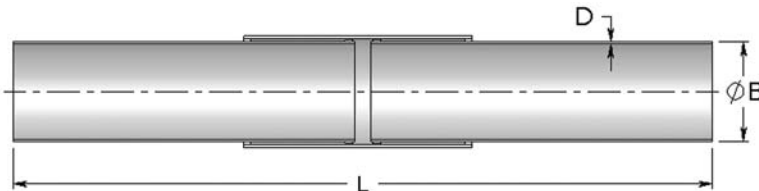

Size		Symbol	ØB	D	L min	L max	ØB	D	L min	L max	
in	mm	No.	inches				millimeters				
2	53	20-2013	2.140	0.070	36	46	54.4	1.8	914.4	1168.4	
2½	63	20-2513	2.640	0.070	36	46	67.1	1.8	914.4	1168.4	
3	78	20-3013	3.140	0.070	36	46	79.8	1.8	914.4	1168.4	
3½	91	20-3513	3.640	0.070	36	46	92.5	1.8	914.4	1168.4	
4	103	20-4013	4.140	0.070	36	46	105.2	1.8	914.4	1168.4	
4½	116	20-4513	4.690	0.095	36	46	119.1	2.4	914.4	1168.4	
5	129	20-5013	5.190	0.095	36	46	131.8	2.4	914.4	1168.4	
6	155	20-6013	6.190	0.095	36	46	157.2	2.4	914.4	1168.4	

ID SW



ID SW SKEW WOBBLE (FOR UP TO 7.5° CURVATURE)

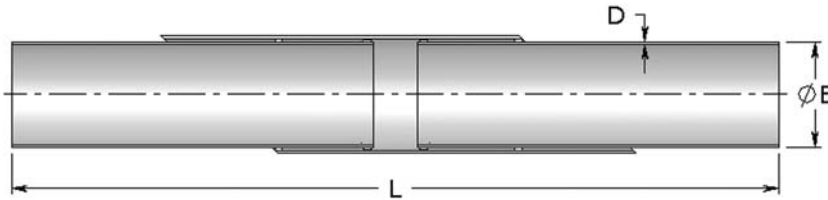

Size		Symbol No.	ØB	D	L min	L max	ØB	D	L min	L max
in	mm		inches				millimeters			
2	53	20-2014	2.140	0.070	48	56	54.4	1.8	1219.2	1422.4
2½	63	20-2514	2.640	0.070	48	56	67.1	1.8	1219.2	1422.4
3	78	20-3014	3.140	0.070	48	56	79.8	1.8	1219.2	1422.4
3½	91	20-3514	3.640	0.070	48	56	92.5	1.8	1219.2	1422.4
4	103	20-4014	4.140	0.070	48	56	105.2	1.8	1219.2	1422.4
4½	116	20-4514	4.690	0.095	48	56	119.1	2.4	1219.2	1422.4
5	129	20-5014	5.190	0.095	48	56	131.8	2.4	1219.2	1422.4
6	155	20-6014	6.190	0.095	48	56	157.2	2.4	1219.2	1422.4

ID SW NPT FEMALE THREADED ADAPTER

Size		Symbol No.	ØC	D	L	X	ØC	D	L	X
in	mm		inches				millimeters			
2	53	20-2044	2.170	0.070	8	0.697	55.1	1.8	203.2	17.7
2½	63	20-2544	2.670	0.070	8	0.932	67.8	1.8	203.2	23.7
3	78	20-3044	3.170	0.070	8	1.016	80.5	1.8	203.2	25.8
3½	91	20-3544	3.670	0.070	8	1.071	93.2	1.8	203.2	27.2
4	103	20-4044	4.170	0.070	8	1.094	105.9	1.8	203.2	27.8
4½	116	20-4544	4.730	0.095	8	1.350	120.1	2.4	203.2	34.3
5	129	20-5044	5.230	0.095	8	1.187	132.8	2.4	203.2	30.1
6	155	20-6044	6.230	0.095	8	1.208	158.2	2.4	203.2	30.7

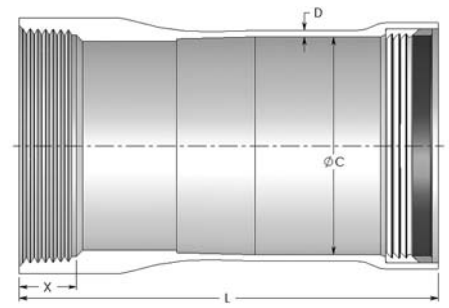

ID SW

ID SW NPT MALE THREADED ADAPTER

Size		Symbol No.	ØC	D	L	X	ØC	D	L	X
in	mm		inches				millimeters			
2	53	20-2027	2.170	0.070	8	0.757	55.1	1.8	203.2	19.2
2½	63	20-2527	2.670	0.070	8	1.138	67.8	1.8	203.2	28.9
3	78	20-3027	3.170	0.070	8	1.200	80.5	1.8	203.2	30.5
3½	91	20-3527	3.670	0.070	8	1.250	93.2	1.8	203.2	31.8
4	103	20-4027	4.170	0.070	8	1.300	105.9	1.8	203.2	33.0
4½	116	20-4527	4.730	0.095	8	1.350	120.1	2.4	203.2	34.3
5	129	20-5027	5.230	0.095	8	1.406	132.8	2.4	203.2	35.7
6	155	20-6027	6.230	0.095	8	1.513	158.2	2.4	203.2	38.4

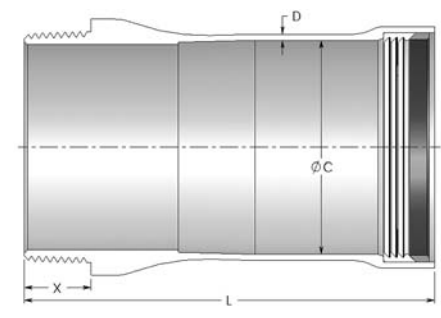

ID SW REDUCER

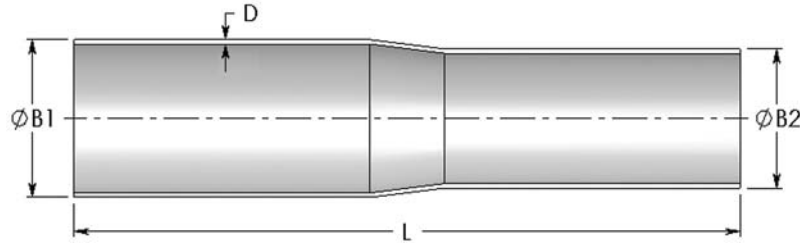

Size		Symbol No.	ØB1	ØB2	D	L	ØB1	ØB2	D	L
in	mm		inches				millimeters			
2	53	20-2029	2.140	1.900	0.070	18	54.4	48.3	1.8	457.2
2½	63	20-2529	2.640	2.140	0.070	18	67.1	54.4	1.8	457.2
3	78	20-3029	3.140	2.640	0.070	18	79.8	67.1	1.8	457.2
3½	91	20-3529	3.640	3.140	0.070	18	92.5	79.8	1.8	457.2
4	103	20-4029	4.140	3.640	0.070	18	105.2	92.5	1.8	457.2
4½	116	20-4529	4.690	4.140	0.095	18	119.1	105.2	2.4	457.2
5	129	20-5029	5.190	4.690	0.095	18	131.8	119.1	2.4	457.2
6	155	20-6029	6.190	5.190	0.095	18	157.2	131.8	2.4	457.2

ID SW MULTIFIT ADAPTER

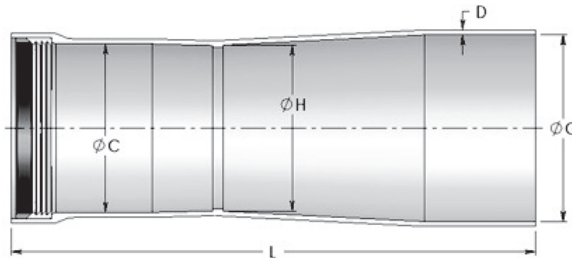

Size		Symbol No.	ØC	D	ØG	ØH	L	ØC	D	ØG	ØH	L
in	mm		inches					millimeters				
2	53	20-2037	2.170	0.070	2.424	2.239	13	55.1	1.8	61.6	56.9	330.2
2½	63	20-2537	2.670	0.070	2.924	2.739	13	67.8	1.8	74.3	69.6	330.2
3	78	20-3037	3.170	0.070	3.549	3.239	13	80.5	1.8	90.1	82.3	330.2
3½	91	20-3537	3.670	0.070	4.061	3.709	13	93.2	1.8	103.1	94.2	330.2
4	103	20-4037	4.170	0.070	4.620	4.109	13	105.9	1.8	117.3	104.4	330.2
4½	116	20-4537	4.730	0.095	4.831	4.750	13	120.1	2.4	122.7	120.7	330.2
5	129	20-5037	5.230	0.095	5.650	5.289	13	132.8	2.4	143.5	134.3	330.2
6	155	20-6037	6.230	0.095	6.686	6.259	13	158.2	2.4	169.8	159.0	330.2

ID SW



ID SW SPLIT STOP RING

Size		Symbol	ØC	D	L	ØC	D	L
in	mm	No.	inches			millimeters		
2	53	20-2064	2.170	0.185	2	55.1	4.7	50.8
2½	63	20-2564	2.670	0.185	2	67.8	4.7	50.8
3	78	20-3064	3.170	0.185	2	80.5	4.7	50.8
3½	91	20-3564	3.670	0.185	2	93.2	4.7	50.8
4	103	20-4064	4.170	0.185	2	105.9	4.7	50.8
4½	116	20-4564	4.730	0.185	2	120.1	4.7	50.8
5	129	20-5064	5.230	0.185	2	132.8	4.7	50.8
6	155	20-6064	6.230	0.185	2	158.2	4.7	50.8

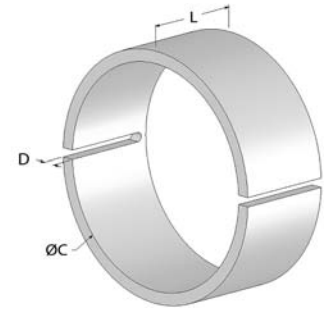

ID SW 11.25° FITTING

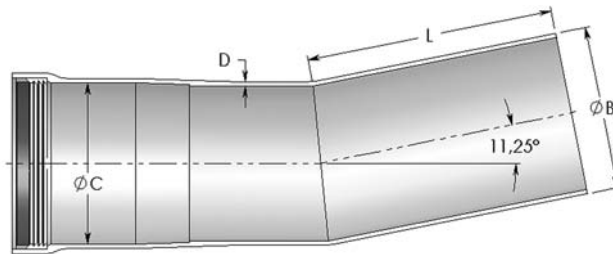

Size		Symbol	ØB	ØC	D	L	ØB	ØC	D	L
in	mm	No.	inches				millimeters			
2	53	20-2035	2.140	2.170	0.070	7	54.4	55.1	1.8	177.8
2½	63	20-2535	2.640	2.670	0.070	7	67.1	67.8	1.8	177.8
3	78	20-3035	3.140	3.170	0.070	7	79.8	80.5	1.8	177.8
3½	91	20-3535	3.640	3.670	0.070	7	92.5	93.2	1.8	177.8
4	103	20-4035	4.140	4.170	0.070	7	105.2	105.9	1.8	177.8
4½	116	20-4535	4.690	4.730	0.095	7	119.1	120.1	2.4	177.8
5	129	20-5035	5.190	5.230	0.095	7	131.8	132.8	2.4	177.8
6	155	20-6035	6.190	6.230	0.095	7	157.2	158.2	2.4	177.8

ID SW 11.25° ELBOW

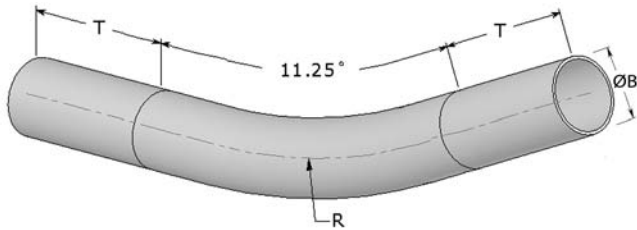

48" RADIUS

Size	Symbol	ØB R T			ØB R T			
		inches			millimeters			
in	mm	No.						
2	53	20-2035R48	2.140	48	6	54.4	1219.2	152.4
2½	63	20-2535R48	2.640	48	6	67.1	1219.2	152.4
3	78	20-3035R48	3.140	48	6	79.8	1219.2	152.4
3½	91	20-3535R48	3.640	48	6	92.5	1219.2	152.4
4	103	20-4035R48	4.140	48	6	105.2	1219.2	152.4
4½	116	20-4535R48	4.690	48	6	119.1	1219.2	152.4
5	129	20-5035R48	5.190	48	6	131.8	1219.2	152.4
6	155	20-6035R48	6.190	48	6	157.2	1219.2	152.4

12" RADIUS

Size	Symbol	ØB R T			ØB R T			
		inches			millimeters			
in	mm	No.						
2	53	20-2035R12	2.140	12	6	54.4	304.8	152.4

60" RADIUS

Size	Symbol	ØB R T			ØB R T			
		inches			millimeters			
in	mm	No.						
2	53	20-2035R60	2.140	60	6	54.4	1524.0	152.4
2½	63	20-2535R60	2.640	60	6	67.1	1524.0	152.4
3	78	20-3035R60	3.140	60	6	79.8	1524.0	152.4
3½	91	20-3535R60	3.640	60	6	92.5	1524.0	152.4
4	103	20-4035R60	4.140	60	6	105.2	1524.0	152.4
4½	116	20-4535R60	4.690	60	6	119.1	1524.0	152.4
5	129	20-5035R60	5.190	60	6	131.8	1524.0	152.4
6	155	20-6035R60	6.190	60	6	157.2	1524.0	152.4

24" RADIUS

Size	Symbol	ØB R T			ØB R T			
		inches			millimeters			
in	mm	No.						
2	53	20-2035R24	2.140	24	6	54.4	609.6	152.4
2½	63	20-2535R24	2.640	24	6	67.1	609.6	152.4
3	78	20-3035R24	3.140	24	6	79.8	609.6	152.4

72" RADIUS

Size	Symbol	ØB R T			ØB R T			
		inches			millimeters			
in	mm	No.						
2	53	20-2035R72	2.140	72	6	54.4	1828.8	152.4
2½	63	20-2535R72	2.640	72	6	67.1	1828.8	152.4
3	78	20-3035R72	3.140	72	6	79.8	1828.8	152.4
3½	91	20-3535R72	3.640	72	6	92.5	1828.8	152.4
4	103	20-4035R72	4.140	72	6	105.2	1828.8	152.4
4½	116	20-4535R72	4.690	72	6	119.1	1828.8	152.4
5	129	20-5035R72	5.190	72	6	131.8	1828.8	152.4
6	155	20-6035R72	6.190	72	6	157.2	1828.8	152.4

36" RADIUS

Size	Symbol	ØB R T			ØB R T			
		inches			millimeters			
in	mm	No.						
2	53	20-2035R36	2.140	36	6	54.4	914.4	152.4
2½	63	20-2535R36	2.640	36	6	67.1	914.4	152.4
3	78	20-3035R36	3.140	36	6	79.8	914.4	152.4
3½	91	20-3535R36	3.640	36	6	92.5	914.4	152.4
4	103	20-4035R36	4.140	36	6	105.2	914.4	152.4
4½	116	20-4535R36	4.690	36	6	119.1	914.4	152.4
5	129	20-5035R36	5.190	36	6	131.8	914.4	152.4

❖ Not UL Listed, CSA Certified or NEMA compliant.



ID SW 22.5° ELBOW

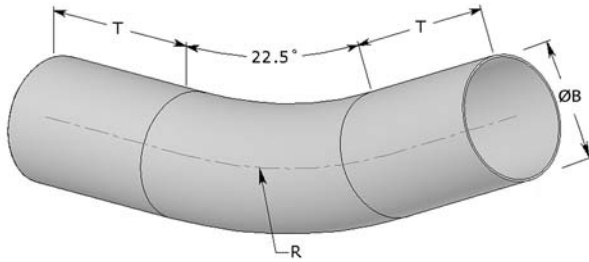

12" RADIUS

Size	Symbol	ØB	R	T	ØB	R	T
in	mm	inches			millimeters		
2	53	20-2034R12	2.140	12	6	54.4	304.8 152.4

24" RADIUS

Size	Symbol	ØB	R	T	ØB	R	T
in	mm	inches			millimeters		
2	53	20-2034R24	2.140	24	6	54.4	609.6 152.4
2½	63	20-2534R24	2.640	24	6	67.1	609.6 152.4
3	78	20-3034R24	3.140	24	6	79.8	609.6 152.4

36" RADIUS

Size	Symbol	ØB	R	T	ØB	R	T
in	mm	inches			millimeters		
2	53	20-2034R36	2.140	36	6	54.4	914.4 152.4
2½	63	20-2534R36	2.640	36	6	67.1	914.4 152.4
3	78	20-3034R36	3.140	36	6	79.8	914.4 152.4
3½	91	20-3534R36	3.640	36	6	92.5	914.4 152.4
4	103	20-4034R36	4.140	36	6	105.2	914.4 152.4
4½	116	20-4534R36	4.690	36	6	119.1	914.4 152.4
5	129	20-5034R36	5.190	36	6	131.8	914.4 152.4

48" RADIUS

Size	Symbol	ØB	R	T	ØB	R	T
in	mm	inches			millimeters		
2	53	20-2034R48	2.140	48	6	54.4	1219.2 152.4
2½	63	20-2534R48	2.640	48	6	67.1	1219.2 152.4
3	78	20-3034R48	3.140	48	6	79.8	1219.2 152.4
3½	91	20-3534R48	3.640	48	6	92.5	1219.2 152.4
4	103	20-4034R48	4.140	48	6	105.2	1219.2 152.4
4½	116	20-4534R48	4.690	48	6	119.1	1219.2 152.4
5	129	20-5034R48	5.190	48	6	131.8	1219.2 152.4
6	155	20-6034R48	6.190	48	6	157.2	1219.2 152.4

60" RADIUS

Size	Symbol	ØB	R	T	ØB	R	T
in	mm	inches			millimeters		
2	53	20-2034R60	2.140	60	6	54.4	1524.0 152.4
2½	63	20-2534R60	2.640	60	6	67.1	1524.0 152.4
3	78	20-3034R60	3.140	60	6	79.8	1524.0 152.4
3½	91	20-3534R60	3.640	60	6	92.5	1524.0 152.4
4	103	20-4034R60	4.140	60	6	105.2	1524.0 152.4
4½	116	20-4534R60	4.690	60	6	119.1	1524.0 152.4
5	129	20-5034R60	5.190	60	6	131.8	1524.0 152.4
6	155	20-6034R60	6.190	60	6	157.2	1524.0 152.4

72" RADIUS

Size	Symbol	ØB	R	T	ØB	R	T
in	mm	inches			millimeters		
2	53	20-2034R72	2.140	72	6	54.4	1828.8 152.4
2½	63	20-2534R72	2.640	72	6	67.1	1828.8 152.4
3	78	20-3034R72	3.140	72	6	79.8	1828.8 152.4
3½	91	20-3534R72	3.640	72	6	92.5	1828.8 152.4
4	103	20-4034R72	4.140	72	6	105.2	1828.8 152.4
4½	116	20-4534R72	4.690	72	6	119.1	1828.8 152.4
5	129	20-5034R72	5.190	72	6	131.8	1828.8 152.4
6	155	20-6034R72	6.190	72	6	157.2	1828.8 152.4

❖ Not UL Listed, CSA Certified or NEMA compliant.



ID SW 30° ELBOW

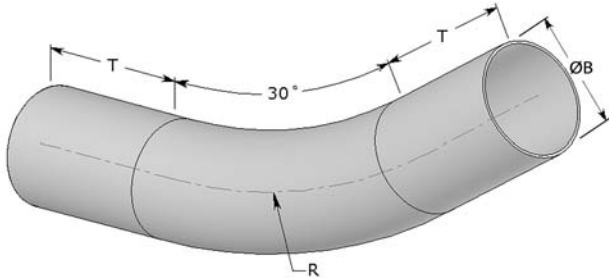

12" RADIUS

Size	Symbol	ØB	R	T	ØB	R	T	
in	mm	inches			millimeters			
2	53	20-2033R12	2.140	12	6	54.4	304.8	152.4

24" RADIUS

Size	Symbol	ØB	R	T	ØB	R	T	
in	mm	inches			millimeters			
2	53	20-2033R24	2.140	24	6	54.4	609.6	152.4
2½	63	20-2533R24	2.640	24	6	67.1	609.6	152.4
3	78	20-3033R24	3.140	24	6	79.8	609.6	152.4

36" RADIUS

Size	Symbol	ØB	R	T	ØB	R	T	
in	mm	inches			millimeters			
2	53	20-2033R36	2.140	36	6	54.4	914.4	152.4
2½	63	20-2533R36	2.640	36	6	67.1	914.4	152.4
3	78	20-3033R36	3.140	36	6	79.8	914.4	152.4
3½	91	20-3533R36	3.640	36	6	92.5	914.4	152.4
4	103	20-4033R36	4.140	36	6	105.2	914.4	152.4
4½	116	20-4533R36	4.690	36	6	119.1	914.4	152.4
5	129	20-5033R36	5.190	36	6	131.8	914.4	152.4

48" RADIUS

Size	Symbol	ØB	R	T	ØB	R	T	
in	mm	inches			millimeters			
2	53	20-2033R48	2.140	48	6	54.4	1219.2	152.4
2½	63	20-2533R48	2.640	48	6	67.1	1219.2	152.4
3	78	20-3033R48	3.140	48	6	79.8	1219.2	152.4
3½	91	20-3533R48	3.640	48	6	92.5	1219.2	152.4
4	103	20-4033R48	4.140	48	6	105.2	1219.2	152.4
4½	116	20-4533R48	4.690	48	6	119.1	1219.2	152.4
5	129	20-5033R48	5.190	48	6	131.8	1219.2	152.4
6	155	20-6033R48	6.190	48	6	157.2	1219.2	152.4

60" RADIUS

Size	Symbol	ØB	R	T	ØB	R	T	
in	mm	inches			millimeters			
2	53	20-2033R60	2.140	60	6	54.4	1524.0	152.4
2½	63	20-2533R60	2.640	60	6	67.1	1524.0	152.4
3	78	20-3033R60	3.140	60	6	79.8	1524.0	152.4
3½	91	20-3533R60	3.640	60	6	92.5	1524.0	152.4
4	103	20-4033R60	4.140	60	6	105.2	1524.0	152.4
4½	116	20-4533R60	4.690	60	6	119.1	1524.0	152.4
5	129	20-5033R60	5.190	60	6	131.8	1524.0	152.4
6	155	20-6033R60	6.190	60	6	157.2	1524.0	152.4

72" RADIUS

Size	Symbol	ØB	R	T	ØB	R	T	
in	mm	inches			millimeters			
2	53	20-2033R72	2.140	72	6	54.4	1828.8	152.4
2½	63	20-2533R72	2.640	72	6	67.1	1828.8	152.4
3	78	20-3033R72	3.140	72	6	79.8	1828.8	152.4
3½	91	20-3533R72	3.640	72	6	92.5	1828.8	152.4
4	103	20-4033R72	4.140	72	6	105.2	1828.8	152.4
4½	116	20-4533R72	4.690	72	6	119.1	1828.8	152.4
5	129	20-5033R72	5.190	72	6	131.8	1828.8	152.4
6	155	20-6033R72	6.190	72	6	157.2	1828.8	152.4

❖ Not UL Listed, CSA Certified or NEMA compliant.



ID SW 45° ELBOW

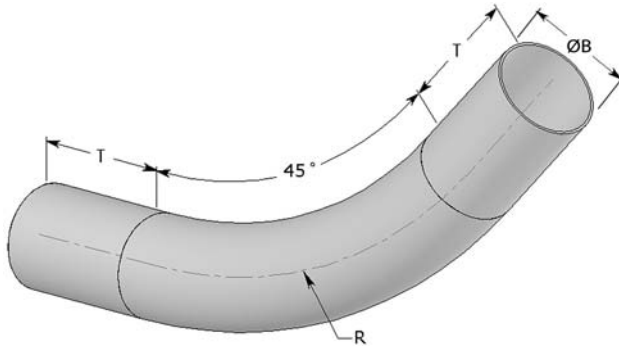

12" RADIUS

Size	Symbol	ØB	R	T	ØB	R	T	
in	mm	inches			millimeters			
2	53	20-2032R12	2.140	12	6	54.4	304.8	152.4

24" RADIUS

Size	Symbol	ØB	R	T	ØB	R	T	
in	mm	inches			millimeters			
2	53	20-2032R24	2.140	24	6	54.4	609.6	152.4
2½	63	20-2532R24	2.640	24	6	67.1	609.6	152.4
3	78	20-3032R24	3.140	24	6	79.8	609.6	152.4

36" RADIUS

Size	Symbol	ØB	R	T	ØB	R	T	
in	mm	inches			millimeters			
2	53	20-2032R36	2.140	36	6	54.4	914.4	152.4
2½	63	20-2532R36	2.640	36	6	67.1	914.4	152.4
3	78	20-3032R36	3.140	36	6	79.8	914.4	152.4
3½	91	20-3532R36	3.640	36	6	92.5	914.4	152.4
4	103	20-4032R36	4.140	36	6	105.2	914.4	152.4
4½	116	20-4532R36	4.690	36	6	119.1	914.4	152.4
5	129	20-5032R36	5.190	36	6	131.8	914.4	152.4

48" RADIUS

Size	Symbol	ØB	R	T	ØB	R	T	
in	mm	inches			millimeters			
2	53	20-2032R48	2.140	48	6	54.4	1219.2	152.4
2½	63	20-2532R48	2.640	48	6	67.1	1219.2	152.4
3	78	20-3032R48	3.140	48	6	79.8	1219.2	152.4
3½	91	20-3532R48	3.640	48	6	92.5	1219.2	152.4
4	103	20-4032R48	4.140	48	6	105.2	1219.2	152.4
4½	116	20-4532R48	4.690	48	6	119.1	1219.2	152.4
5	129	20-5032R48	5.190	48	6	131.8	1219.2	152.4
6	155	20-6032R48	6.190	48	6	157.2	1219.2	152.4

60" RADIUS

Size	Symbol	ØB	R	T	ØB	R	T	
in	mm	inches			millimeters			
2	53	20-2032R60	2.140	60	6	54.4	1524.0	152.4
2½	63	20-2532R60	2.640	60	6	67.1	1524.0	152.4
3	78	20-3032R60	3.140	60	6	79.8	1524.0	152.4
3½	91	20-3532R60	3.640	60	6	92.5	1524.0	152.4
4	103	20-4032R60	4.140	60	6	105.2	1524.0	152.4
4½	116	20-4532R60	4.690	60	6	119.1	1524.0	152.4
5	129	20-5032R60	5.190	60	6	131.8	1524.0	152.4
6	155	20-6032R60	6.190	60	6	157.2	1524.0	152.4

72" RADIUS

Size	Symbol	ØB	R	T	ØB	R	T	
in	mm	inches			millimeters			
2	53	20-2032R72	2.140	72	6	54.4	1828.8	152.4
2½	63	20-2532R72	2.640	72	6	67.1	1828.8	152.4
3	78	20-3032R72	3.140	72	6	79.8	1828.8	152.4
3½	91	20-3532R72	3.640	72	6	92.5	1828.8	152.4
4	103	20-4032R72	4.140	72	6	105.2	1828.8	152.4
4½	116	20-4532R72	4.690	72	6	119.1	1828.8	152.4
5	129	20-5032R72	5.190	72	6	131.8	1828.8	152.4
6	155	20-6032R72	6.190	72	6	157.2	1828.8	152.4

❖ Not UL Listed, CSA Certified or NEMA compliant.



ID SW 60° ELBOW

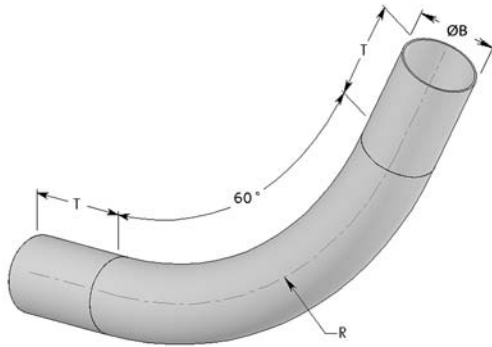

48" RADIUS

Size	Symbol	ØB	R	T	ØB	R	T	
in	mm	inches			millimeters			
2	53	20-2031R48	2.140	48	6	54.4	1219.2	152.4
2½	63	20-2531R48	2.640	48	6	67.1	1219.2	152.4
3	78	20-3031R48	3.140	48	6	79.8	1219.2	152.4
3½	91	20-3531R48	3.640	48	6	92.5	1219.2	152.4
4	103	20-4031R48	4.140	48	6	105.2	1219.2	152.4
4½	116	20-4531R48	4.690	48	6	119.1	1219.2	152.4
5	129	20-5031R48	5.190	48	6	131.8	1219.2	152.4
6	155	20-6031R48	6.190	48	6	157.2	1219.2	152.4

12" RADIUS

Size	Symbol	ØB	R	T	ØB	R	T	
in	mm	inches			millimeters			
2	53	20-2031R12	2.140	12	6	54.4	304.8	152.4

60" RADIUS

Size	Symbol	ØB	R	T	ØB	R	T	
in	mm	inches			millimeters			
2	53	20-2031R60	2.140	60	6	54.4	1524.0	152.4
2½	63	20-2531R60	2.640	60	6	67.1	1524.0	152.4
3	78	20-3031R60	3.140	60	6	79.8	1524.0	152.4
3½	91	20-3531R60	3.640	60	6	92.5	1524.0	152.4
4	103	20-4031R60	4.140	60	6	105.2	1524.0	152.4
4½	116	20-4531R60	4.690	60	6	119.1	1524.0	152.4
5	129	20-5031R60	5.190	60	6	131.8	1524.0	152.4
6	155	20-6031R60	6.190	60	6	157.2	1524.0	152.4

24" RADIUS

Size	Symbol	ØB	R	T	ØB	R	T	
in	mm	inches			millimeters			
2	53	20-2031R24	2.140	24	6	54.4	609.6	152.4
2½	63	20-2531R24	2.640	24	6	67.1	609.6	152.4
3	78	20-3031R24	3.140	24	6	79.8	609.6	152.4

72" RADIUS

Size	Symbol	ØB	R	T	ØB	R	T	
in	mm	inches			millimeters			
2	53	20-2031R72	2.140	72	6	54.4	1828.8	152.4
2½	63	20-2531R72	2.640	72	6	67.1	1828.8	152.4
3	78	20-3031R72	3.140	72	6	79.8	1828.8	152.4
3½	91	20-3531R72	3.640	72	6	92.5	1828.8	152.4
4	103	20-4031R72	4.140	72	6	105.2	1828.8	152.4
4½	116	20-4531R72	4.690	72	6	119.1	1828.8	152.4
5	129	20-5031R72	5.190	72	6	131.8	1828.8	152.4
6	155	20-6031R72	6.190	72	6	157.2	1828.8	152.4

36" RADIUS

Size	Symbol	ØB	R	T	ØB	R	T	
in	mm	inches			millimeters			
2	53	20-2031R36	2.140	36	6	54.4	914.4	152.4
2½	63	20-2531R36	2.640	36	6	67.1	914.4	152.4
3	78	20-3031R36	3.140	36	6	79.8	914.4	152.4
3½	91	20-3531R36	3.640	36	6	92.5	914.4	152.4
4	103	20-4031R36	4.140	36	6	105.2	914.4	152.4
4½	116	20-4531R36	4.690	36	6	119.1	914.4	152.4
5	129	20-5031R36	5.190	36	6	131.8	914.4	152.4

❖ Not UL Listed, CSA Certified or NEMA compliant.



ID SW

ID SW 90° ELBOW

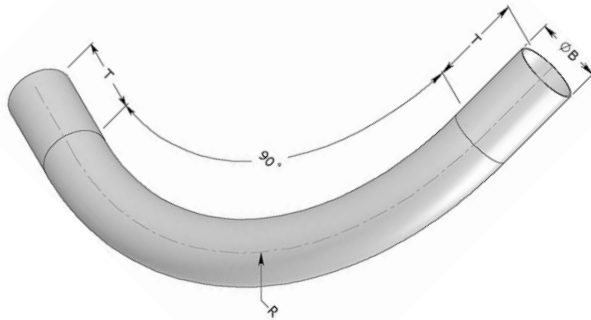

12" RADIUS

Size	Symbol	ØB	R	T	ØB	R	T	
in	mm	inches			millimeters			
2	53	20-2030R12	2.140	12	6	54.4	304.8	152.4

18" RADIUS

Size	Symbol	ØB	R	T	ØB	R	T	
in	mm	inches			millimeters			
2	53	20-2030R18	2.140	18	6	54.4	457.2	152.4
2½	63	20-2530R18	2.640	18	6	67.1	457.2	152.4

24" RADIUS

Size	Symbol	ØB	R	T	ØB	R	T	
in	mm	inches			millimeters			
2	53	20-2030R24	2.140	24	6	54.4	609.6	152.4
2½	63	20-2530R24	2.640	24	6	67.1	609.6	152.4
3	78	20-3030R24	3.140	24	6	79.8	609.6	152.4

36" RADIUS

Size	Symbol	ØB	R	T	ØB	R	T	
in	mm	inches			millimeters			
2	53	20-2030R36	2.140	36	6	54.4	914.4	152.4
2½	63	20-2530R36	2.640	36	6	67.1	914.4	152.4
3	78	20-3030R36	3.140	36	6	79.8	914.4	152.4
3½	91	20-3530R36	3.640	36	6	92.5	914.4	152.4
4	103	20-4030R36	4.140	36	6	105.2	914.4	152.4
4½	116	20-4530R36	4.690	36	6	119.1	914.4	152.4
5	129	20-5030R36	5.190	36	6	131.8	914.4	152.4
6	155	20-6030R36	6.190	36	6	157.2	914.4	152.4

48" RADIUS

Size	Symbol	ØB	R	T	ØB	R	T	
in	mm	inches			millimeters			
2	53	20-2030R48	2.140	48	6	54.4	1219.2	152.4
2½	63	20-2530R48	2.640	48	6	67.1	1219.2	152.4
3	78	20-3030R48	3.140	48	6	79.8	1219.2	152.4
3½	91	20-3530R48	3.640	48	6	92.5	1219.2	152.4
4	103	20-4030R48	4.140	48	6	105.2	1219.2	152.4
4½	116	20-4530R48	4.690	48	6	119.1	1219.2	152.4
5	129	20-5030R48	5.190	48	6	131.8	1219.2	152.4
6	155	20-6030R48	6.190	48	6	157.2	1219.2	152.4

60" RADIUS

Size	Symbol	ØB	R	T	ØB	R	T	
in	mm	inches			millimeters			
2	53	20-2030R60	2.140	60	6	54.4	1524.0	152.4
2½	63	20-2530R60	2.640	60	6	67.1	1524.0	152.4
3	78	20-3030R60	3.140	60	6	79.8	1524.0	152.4
3½	91	20-3530R60	3.640	60	6	92.5	1524.0	152.4
4	103	20-4030R60	4.140	60	6	105.2	1524.0	152.4
4½	116	20-4530R60	4.690	60	6	119.1	1524.0	152.4
5	129	20-5030R60	5.190	60	6	131.8	1524.0	152.4
6	155	20-6030R60	6.190	60	6	157.2	1524.0	152.4

72" RADIUS

Size	Symbol	ØB	R	T	ØB	R	T	
in	mm	inches			millimeters			
2	53	20-2030R72	2.140	72	6	54.4	1828.8	152.4
2½	63	20-2530R72	2.640	72	6	67.1	1828.8	152.4
3	78	20-3030R72	3.140	72	6	79.8	1828.8	152.4
3½	91	20-3530R72	3.640	72	6	92.5	1828.8	152.4
4	103	20-4030R72	4.140	72	6	105.2	1828.8	152.4
4½	116	20-4530R72	4.690	72	6	119.1	1828.8	152.4
5	129	20-5030R72	5.190	72	6	131.8	1828.8	152.4
6	155	20-6030R72	6.190	72	6	157.2	1828.8	152.4

ID SW

❖ Not UL Listed, CSA Certified or NEMA compliant.



ID SW RISERWAY

Size	Symbol	ØB	ØC	D	L	ØB	ØC	D	L	
in	mm	inches				millimeters				m
2 ❖ 53	20-2440	2.140	2.170	0.235	118	54.4	55.1	6.0	3	
2½ ❖ 63	20-2940	2.640	2.670	0.235	118	67.1	67.8	6.0	3	
3 ❖ 78	20-3440	3.140	3.170	0.235	118	79.8	80.5	6.0	3	
3½ ❖ 91	20-3940	3.640	3.670	0.235	118	92.5	93.2	6.0	3	
4 ❖ 103	20-4440	4.140	4.170	0.235	118	105.2	105.9	6.0	3	
4½ ❖ 116	20-4940	4.690	4.730	0.235	118	119.1	120.1	6.0	3	
5 ❖ 129	20-5440	5.190	5.230	0.235	118	131.8	132.8	6.0	3	
6 ❖ 155	20-6440	6.190	6.230	0.235	118	157.2	158.2	6.0	3	

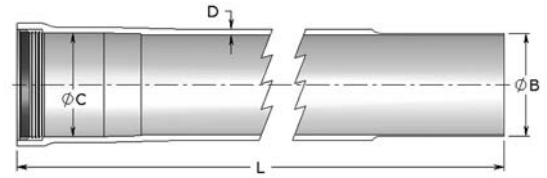

ID SW OFFSET ELBOW

Size	Symbol
all	special

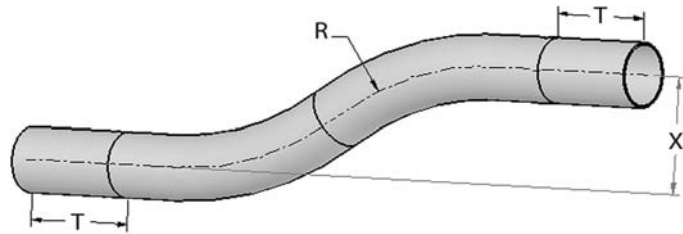

ID SW CONDUIT BODIES

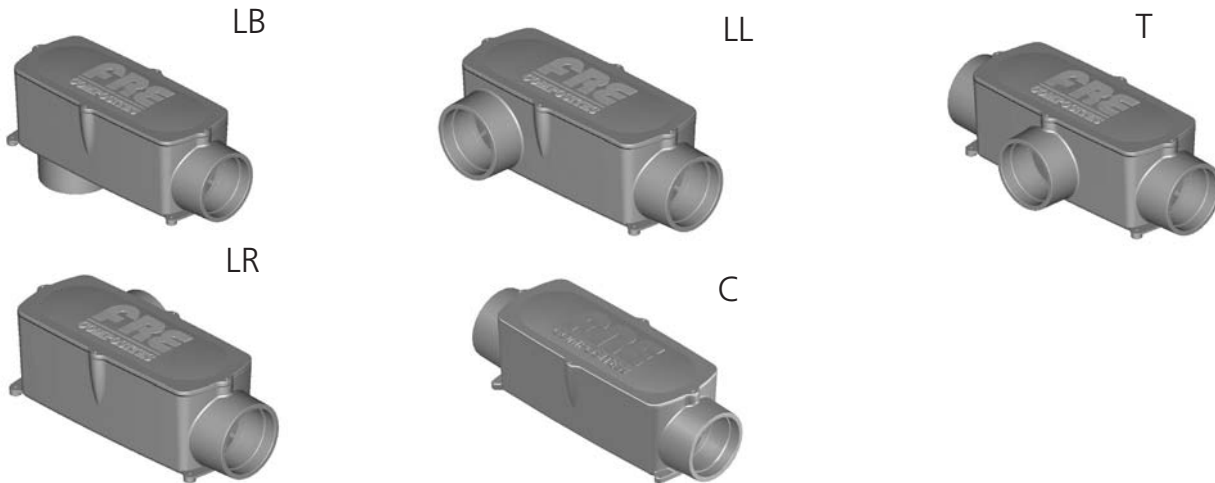

Size	Part number					Length	Width	Depth	Length Width Depth			
	LB	LL	LR	T	C				inches	millimeters		
2	53	20-2091	20-2092	20-2093	20-2094	20-2095	8.75	3.88	3.34	222	99	85
2½	63	20-2591	20-2592	20-2593	20-2594	20-2595	9.88	4.38	3.75	251	111	95
3	78	20-3091	20-3092	20-3093	20-3094	20-3095	11.88	5.13	4.38	302	130	111
3½	91	20-3591	20-3592	20-3593	20-3594	20-3595	13.75	5.75	5.00	349	146	127
4*	103	20-4091	20-4092	20-4093	20-4094	20-4095	16.38	7.00	6.25	416	178	159

* Consult factory for availability

❖ Not UL Listed, CSA Certified or NEMA compliant.



ID HEAVY WALL (HW) FOR ENHANCED MECHANICAL PROPERTIES

ID HEAVY WALL (HW) CONDUIT

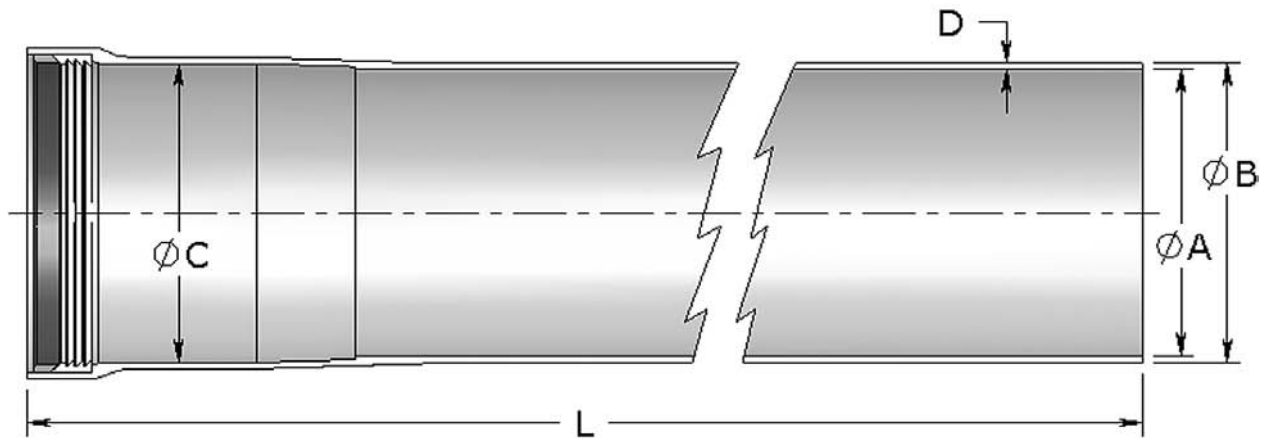

Size	Symbol	ØA	ØB	ØC	D	L	ØA	ØB	ØC	D	L	
in	mm	inches					millimeters					meters
4	103	22-4000	4.000	4.190	4.230	0.095	236.25	101.6	106.4	107.4	2.4	6
4½	116	22-4500	4.500	4.730	4.770	0.115	236.25	114.3	120.1	121.2	2.9	6
5	129	22-5000	5.000	5.230	5.270	0.115	236.25	127.0	132.8	133.9	2.9	6
6	155	22-6000	6.000	6.230	6.270	0.115	236.25	152.4	158.2	159.3	2.9	6

- All our ID Above Ground products are offered with a TriSeal™ for a push-fit assembly.
- Adhesives are available, if required.
- Standard length is 19.68 ft. (6m) but can also be available in 9.84 ft. section (3m), if required.
- Spigot end tapered for ease of installation.



ID HW DOUBLE BELL COUPLING

Size		Symbol	ØC	D	L	ØC	D	L
in	mm	No.	inches			millimeters		
4	103	22-4010	4.230	0.095	10.25	107.4	2.4	260.4
4½	116	22-4510	4.770	0.115	10.25	121.2	2.9	260.4
5	129	22-5010	5.270	0.115	10.25	133.9	2.9	260.4
6	155	22-6010	6.270	0.115	10.25	159.3	2.9	260.4

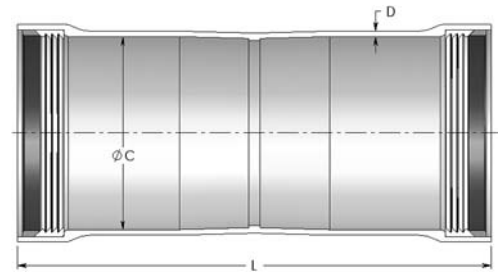

ID HW 5° DOUBLE BELL COUPLING

Size		Symbol	ØC	D	L	ØC	D	L
in	mm	No.	inches			millimeters		
4	103	22-4011	4.230	0.095	0.125	107.4	2.4	3.2
4½	116	22-4511	4.770	0.115	0.125	121.2	2.9	3.2
5	129	22-5011	5.270	0.115	0.125	133.9	2.9	3.2
6	155	22-6011	6.270	0.115	0.125	159.3	2.9	3.2

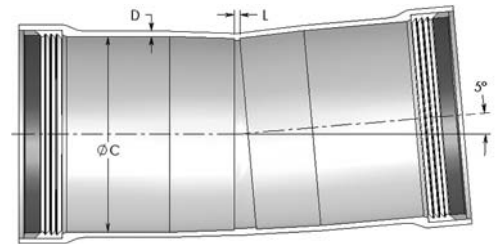

ID HW SLEEVE

Size		Symbol	ØC	D	L	ØC	D	L
in	mm	No.	inches			millimeters		
4	103	22-4016	4.230	0.095	12	107.4	2.4	304.8
4½	116	22-4516	4.770	0.115	12	121.2	2.9	304.8
5	129	22-5016	5.270	0.115	12	133.9	2.9	304.8
6	155	22-6016	6.270	0.115	12	159.3	2.9	304.8

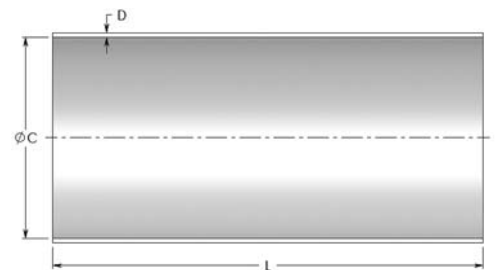

ID HW SINGLE EXPANSION JOINT

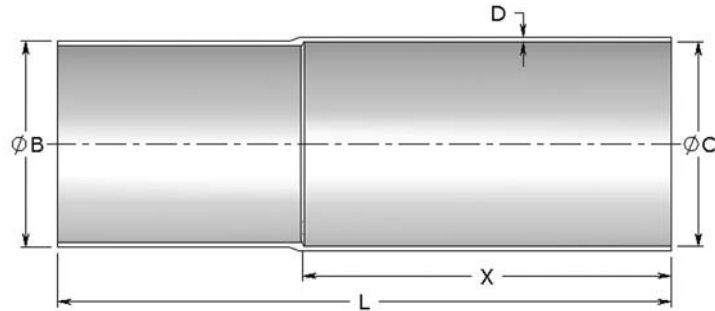

Size		Symbol	ØB	ØC	D	L	X	ØB	ØC	D	L	X
in	mm	No.	inches					millimeters				
4	103	22-4012	4.190	4.230	0.095	20	12	106.4	107.4	2.4	508.0	304.8
4½	116	22-4512	4.730	4.770	0.115	20	12	120.1	121.2	2.9	508.0	304.8
5	129	22-5012	5.230	5.270	0.115	20	12	132.8	133.9	2.9	508.0	304.8
6	155	22-6012	6.230	6.270	0.115	20	12	158.2	159.3	2.9	508.0	304.8

ID HW O-RING EXPANSION JOINT

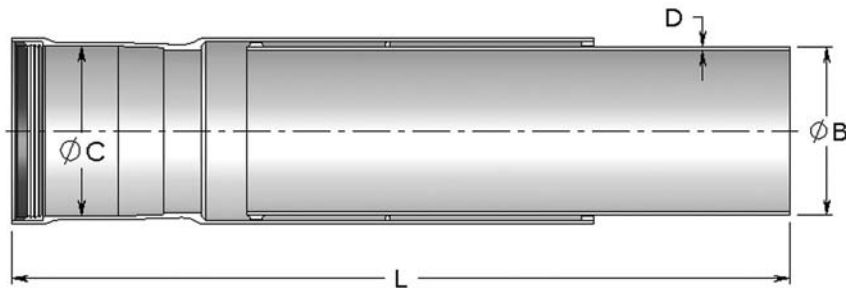

Size		Symbol	ØB	ØC	D	L min	L max	ØB	ØC	D	L min	L max
in	mm	No.	inches					millimeters				
4	103	22-4017	4.190	4.230	0.095	24	36	106.4	107.4	2.4	609.6	914.4
4½	116	22-4517	4.730	4.770	0.115	24	36	120.1	121.2	2.9	609.6	914.4
5	129	22-5017	5.230	5.270	0.115	24	36	132.8	133.9	2.9	609.6	914.4
6	155	22-6017	6.230	6.270	0.115	24	36	158.2	159.3	2.9	609.6	914.4



ID HW O-RING EXPANSION / DEFLECTION JOINT

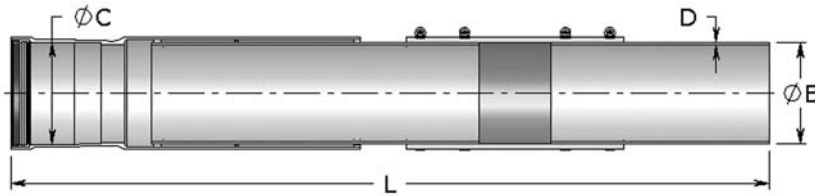

Size	Symbol	ØB	ØC	D	L min	L max	ØB	ØC	D	L min	L max	
in	mm	inches					millimeters					
4	103	22-4057	4.190	4.230	0.095	40	52	106.4	107.4	2.4	1016.0	1320.8
4½	116	22-4557	4.730	4.770	0.115	40	52	120.1	121.2	2.9	1016.0	1320.8
5	129	22-5057	5.230	5.270	0.115	40	52	132.8	133.9	2.9	1016.0	1320.8
6	155	22-6057	6.230	6.270	0.115	40	52	158.2	159.3	2.9	1016.0	1320.8

ID HW WOBBLE (FOR UP TO 3° CURVATURE)

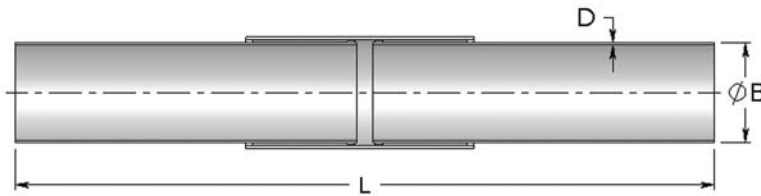

Size	Symbol	ØB	D	L min	L max	ØB	D	L min	L max	
in	mm	inches				millimeters				
4	103	22-4013	4.190	0.095	36	46	106.4	2.4	914.4	1168.4
4½	116	22-4513	4.730	0.115	36	46	120.1	2.9	914.4	1168.4
5	129	22-5013	5.230	0.115	36	46	132.8	2.9	914.4	1168.4
6	155	22-6013	6.230	0.115	36	46	158.2	2.9	914.4	1168.4

ID HW SKEW WOBBLE (FOR UP TO 7.5° CURVATURE)

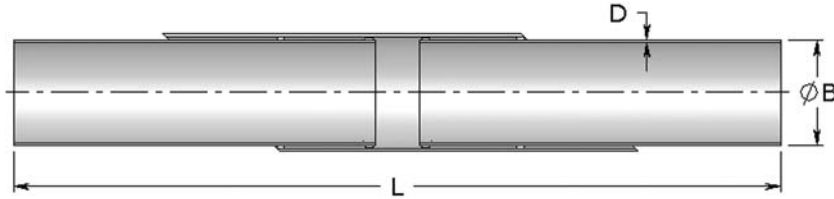

Size		Symbol No.	ØB	D	L min	L max	ØB	D	L min	L max
in	mm		inches				millimeters			
4	103	22-4014	4.190	0.095	48	56	106.4	2.4	1219.2	1422.4
4½	116	22-4514	4.730	0.115	48	56	120.1	2.9	1219.2	1422.4
5	129	22-5014	5.230	0.115	48	56	132.8	2.9	1219.2	1422.4
6	155	22-6014	6.230	0.115	48	56	158.2	2.9	1219.2	1422.4

ID HW NPT FEMALE THREADED ADAPTER

Size		Symbol No.	ØC	D	L	X	ØC	D	L	X
in	mm		inches				millimeters			
4	103	22-4044	4.230	0.095	8	1.094	107.4	2.4	203.2	27.8
4½	116	22-4544	4.770	0.115	8	1.350	121.2	2.9	203.2	34.3
5	129	22-5044	5.270	0.115	8	1.187	133.9	2.9	203.2	30.1
6	155	22-6044	6.270	0.115	8	1.208	159.3	2.9	203.2	30.7

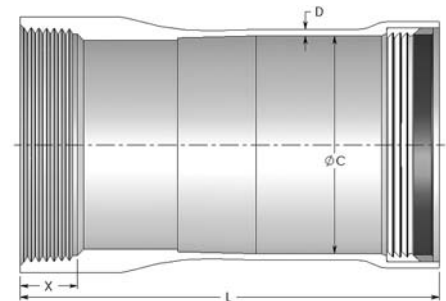

ID HW NPT MALE THREADED ADAPTER

Size		Symbol No.	ØC	D	L	X	ØC	D	L	X
in	mm		inches				millimeters			
4	103	22-4027	4.230	0.095	8	1.300	107.4	2.4	203.2	33.0
4½	116	22-4527	4.770	0.115	8	1.350	121.2	2.9	203.2	34.3
5	129	22-5027	5.270	0.115	8	1.406	133.9	2.9	203.2	35.7
6	155	22-6027	6.270	0.115	8	1.513	159.3	2.9	203.2	38.4

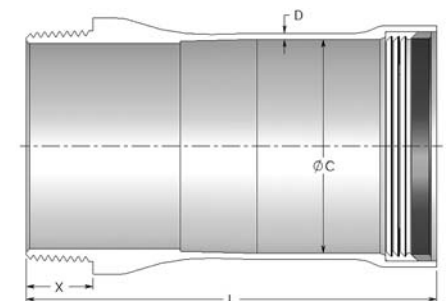

ID HW



ID HW REDUCER

Size	Symbol	ØB1	ØB2	D	L	ØB1	ØB2	D	L	
in	mm	inches				millimeters				
4	103	22-4029	4.190	3.690	0.095	18	106.4	93.7	2.4	457.2
4½	116	22-4529	4.730	4.190	0.115	18	120.1	106.4	2.9	457.2
5	129	22-5029	5.230	4.730	0.115	18	132.8	120.1	2.9	457.2
6	155	22-6029	6.230	5.230	0.115	18	158.2	132.8	2.9	457.2

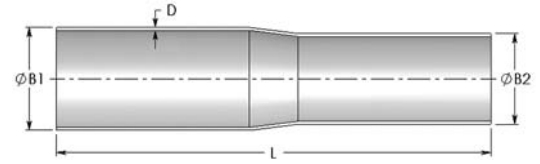

ID HW SPLIT STOP RING

Size	Symbol	ØC	D	L	ØC	D	L	
in	mm	inches			millimeters			
4	103	22-4064	4.230	0.185	2	107.4	4.7	50.8
4½	116	22-4564	4.770	0.185	2	121.2	4.7	50.8
5	129	22-5064	5.270	0.185	2	133.9	4.7	50.8
6	155	22-6064	6.270	0.185	2	259.3	4.7	50.8

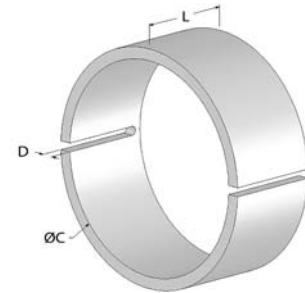

ID HW MULTIFIT ADAPTER

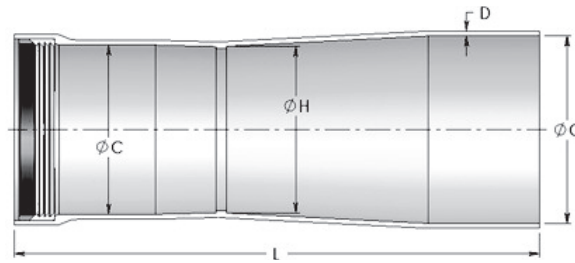

Size	Symbol	ØC	D	ØG	ØH	L	ØC	D	ØG	ØH	L	
in	mm	inches					millimeters					
4	103	22-4037	4.230	0.095	4.620	4.109	13	107.4	2.4	117.3	104.4	330.2
4½	116	22-4537	4.770	0.115	4.831	4.750	13	121.2	2.9	122.7	120.7	330.2
5	129	22-5037	5.270	0.115	5.650	5.289	13	133.9	2.9	143.5	134.3	330.2
6	155	22-6037	6.270	0.115	6.686	6.259	13	159.3	2.9	169.8	159.0	330.2

ID HW 11.25° FITTING

Size	Symbol	ØB	ØC	D	L	ØB	ØC	D	L	
in	mm	inches				millimeters				
4	103	22-4035	4.190	4.230	0.095	7	106.4	107.4	2.4	177.8
4½	116	22-4535	4.730	4.770	0.115	7	120.1	121.2	2.9	177.8
5	129	22-5035	5.230	5.270	0.115	7	132.8	133.9	2.9	177.8
6	155	22-6035	6.230	6.270	0.115	7	158.2	159.3	2.9	177.8

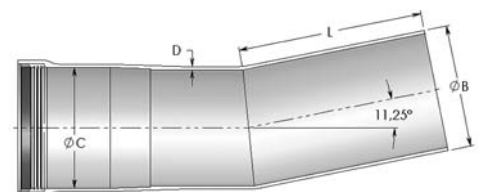

ID HW 11.25° ELBOW

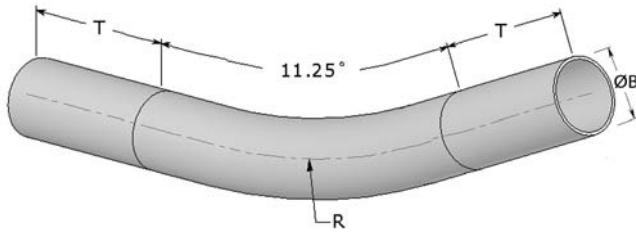

ID HW 22.5° ELBOW

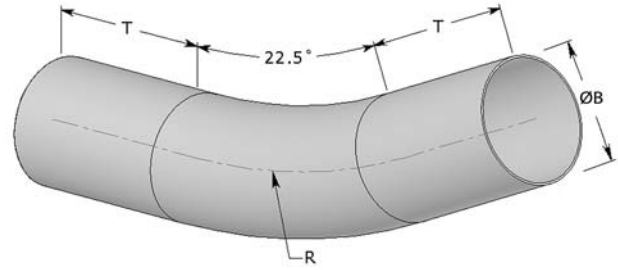

36" RADIUS

Size	Symbol	ØB	R	T	ØB	R	T	
in	mm	inches			millimeters			
	No.							
4	103	22-4035R36	4.190	36	6	106.4	914.4	152.4
4½	116	22-4535R36	4.730	36	6	120.1	914.4	152.4
5	129	22-5035R36	5.230	36	6	132.8	914.4	152.4

36" RADIUS

Size	Symbol	ØB	R	T	ØB	R	T	
in	mm	inches			millimeters			
	No.							
4	103	22-4034R36	4.190	36	6	106.4	914.4	152.4
4½	116	22-4534R36	4.730	36	6	120.1	914.4	152.4
5	129	22-5034R36	5.230	36	6	132.8	914.4	152.4

48" RADIUS

Size	Symbol	ØB	R	T	ØB	R	T	
in	mm	inches			millimeters			
	No.							
4	103	22-4035R48	4.190	48	6	106.4	1219.2	152.4
4½	116	22-4535R48	4.730	48	6	120.1	1219.2	152.4
5	129	22-5035R48	5.230	48	6	132.8	1219.2	152.4
6	155	22-6035R48	6.230	48	6	158.2	1219.2	152.4

48" RADIUS

Size	Symbol	ØB	R	T	ØB	R	T	
in	mm	inches			millimeters			
	No.							
4	103	22-4034R48	4.190	48	6	106.4	1219.2	152.4
4½	116	22-4534R48	4.730	48	6	120.1	1219.2	152.4
5	129	22-5034R48	5.230	48	6	132.8	1219.2	152.4
6	155	22-6034R48	6.230	48	6	158.2	1219.2	152.4

60" RADIUS

Size	Symbol	ØB	R	T	ØB	R	T	
in	mm	inches			millimeters			
	No.							
4	103	22-4035R60	4.190	60	6	106.4	1524.0	152.4
4½	116	22-4535R60	4.730	60	6	120.1	1524.0	152.4
5	129	22-5035R60	5.230	60	6	132.8	1524.0	152.4
6	155	22-6035R60	6.230	60	6	158.2	1524.0	152.4

60" RADIUS

Size	Symbol	ØB	R	T	ØB	R	T	
in	mm	inches			millimeters			
	No.							
4	103	22-4034R60	4.190	60	6	106.4	1524.0	152.4
4½	116	22-4534R60	4.730	60	6	120.1	1524.0	152.4
5	129	22-5034R60	5.230	60	6	132.8	1524.0	152.4
6	155	22-6034R60	6.230	60	6	158.2	1524.0	152.4

72" RADIUS

Size	Symbol	ØB	R	T	ØB	R	T	
in	mm	inches			millimeters			
	No.							
4	103	22-4035R72	4.190	72	6	106.4	1828.8	152.4
4½	116	22-4535R72	4.730	72	6	120.1	1828.8	152.4
5	129	22-5035R72	5.230	72	6	132.8	1828.8	152.4
6	155	22-6035R72	6.230	72	6	158.2	1828.8	152.4

72" RADIUS

Size	Symbol	ØB	R	T	ØB	R	T	
in	mm	inches			millimeters			
	No.							
4	103	22-4034R72	4.190	72	6	106.4	1828.8	152.4
4½	116	22-4534R72	4.730	72	6	120.1	1828.8	152.4
5	129	22-5034R72	5.230	72	6	132.8	1828.8	152.4
6	155	22-6034R72	6.230	72	6	158.2	1828.8	152.4



ID HW 30° ELBOW

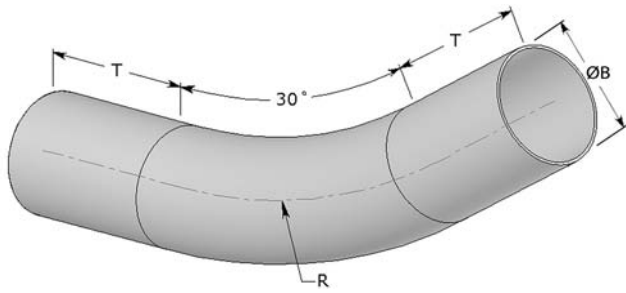

ID HW 45° ELBOW

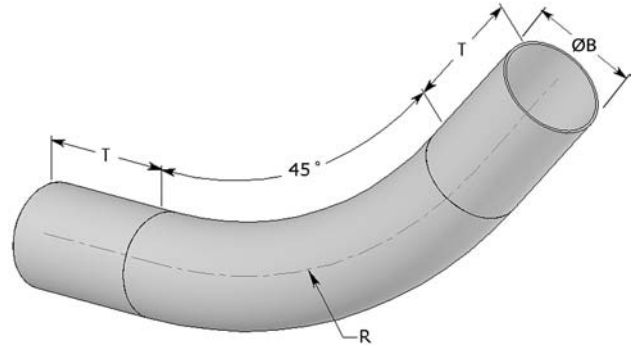

36" RADIUS

Size	Symbol	ØB	R	T	ØB	R	T	
in	mm	inches			millimeters			
	No.							
4	103	22-4033R36	4.190	36	6	106.4	914.4	152.4
4½	116	22-4533R36	4.730	36	6	120.1	914.4	152.4
5	129	22-5033R36	5.230	36	6	132.8	914.4	152.4

36" RADIUS

Size	Symbol	ØB	R	T	ØB	R	T	
in	mm	inches			millimeters			
	No.							
4	103	22-4032R36	4.190	36	6	106.4	914.4	152.4
4½	116	22-4532R36	4.730	36	6	120.1	914.4	152.4
5	129	22-5032R36	5.230	36	6	132.8	914.4	152.4

48" RADIUS

Size	Symbol	ØB	R	T	ØB	R	T	
in	mm	inches			millimeters			
	No.							
4	103	22-4033R48	4.190	48	6	106.4	1219.2	152.4
4½	116	22-4533R48	4.730	48	6	120.1	1219.2	152.4
5	129	22-5033R48	5.230	48	6	132.8	1219.2	152.4
6	155	22-6033R48	6.230	48	6	158.2	1219.2	152.4

48" RADIUS

Size	Symbol	ØB	R	T	ØB	R	T	
in	mm	inches			millimeters			
	No.							
4	103	22-4032R48	4.190	48	6	106.4	1219.2	152.4
4½	116	22-4532R48	4.730	48	6	120.1	1219.2	152.4
5	129	22-5032R48	5.230	48	6	132.8	1219.2	152.4
6	155	22-6032R48	6.230	48	6	158.2	1219.2	152.4

60" RADIUS

Size	Symbol	ØB	R	T	ØB	R	T	
in	mm	inches			millimeters			
	No.							
4	103	22-4033R60	4.190	60	6	106.4	1524.0	152.4
4½	116	22-4533R60	4.730	60	6	120.1	1524.0	152.4
5	129	22-5033R60	5.230	60	6	132.8	1524.0	152.4
6	155	22-6033R60	6.230	60	6	158.2	1524.0	152.4

60" RADIUS

Size	Symbol	ØB	R	T	ØB	R	T	
in	mm	inches			millimeters			
	No.							
4	103	22-4032R60	4.190	60	6	106.4	1524.0	152.4
4½	116	22-4532R60	4.730	60	6	120.1	1524.0	152.4
5	129	22-5032R60	5.230	60	6	132.8	1524.0	152.4
6	155	22-6032R60	6.230	60	6	158.2	1524.0	152.4

72" RADIUS

Size	Symbol	ØB	R	T	ØB	R	T	
in	mm	inches			millimeters			
	No.							
4	103	22-4033R72	4.190	72	6	106.4	1828.8	152.4
4½	116	22-4533R72	4.730	72	6	120.1	1828.8	152.4
5	129	22-5033R72	5.230	72	6	132.8	1828.8	152.4
6	155	22-6033R72	6.230	72	6	158.2	1828.8	152.4

72" RADIUS

Size	Symbol	ØB	R	T	ØB	R	T	
in	mm	inches			millimeters			
	No.							
4	103	22-4032R72	4.190	72	6	106.4	1828.8	152.4
4½	116	22-4532R72	4.730	72	6	120.1	1828.8	152.4
5	129	22-5032R72	5.230	72	6	132.8	1828.8	152.4
6	155	22-6032R72	6.230	72	6	158.2	1828.8	152.4



ID HW 60° ELBOW

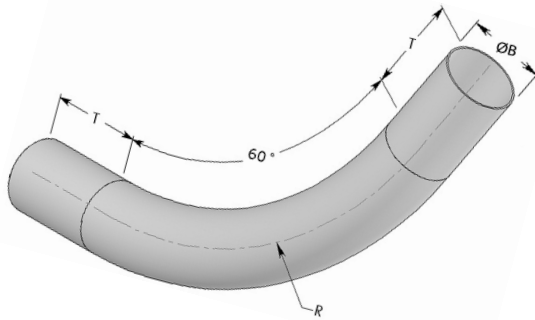

ID HW 90° ELBOW

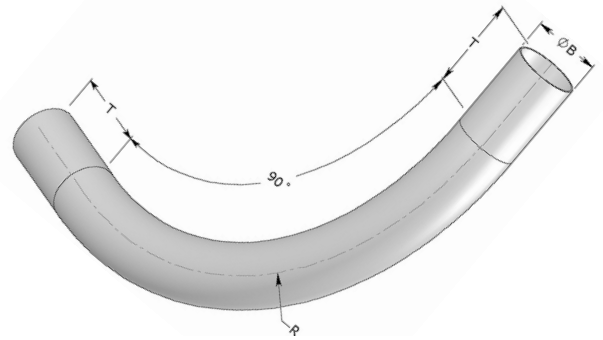

36" RADIUS

Size	Symbol	ØB	R	T	ØB	R	T	
in	mm	inches			millimeters			
	No.							
4	103	22-4031R36	4.190	36	6	106.4	914.4	152.4
4½	116	22-4531R36	4.730	36	6	120.1	914.4	152.4
5	129	22-5031R36	5.230	36	6	132.8	914.4	152.4

36" RADIUS

Size	Symbol	ØB	R	T	ØB	R	T	
in	mm	inches			millimeters			
	No.							
4	103	22-4030R36	4.190	36	6	106.4	914.4	152.4
4½	116	22-4530R36	4.730	36	6	120.1	914.4	152.4

48" RADIUS

Size	Symbol	ØB	R	T	ØB	R	T	
in	mm	inches			millimeters			
	No.							
4	103	22-4031R48	4.190	48	6	106.4	1219.2	152.4
4½	116	22-4531R48	4.730	48	6	120.1	1219.2	152.4
5	129	22-5031R48	5.230	48	6	132.8	1219.2	152.4
6	155	22-6031R48	6.230	48	6	158.2	1219.2	152.4

48" RADIUS

Size	Symbol	ØB	R	T	ØB	R	T	
in	mm	inches			millimeters			
	No.							
4	103	22-4030R48	4.190	48	6	106.4	1219.2	152.4
4½	116	22-4530R48	4.730	48	6	120.1	1219.2	152.4
5	129	22-5030R48	5.230	48	6	132.8	1219.2	152.4
6	155	22-6030R48	6.230	48	6	158.2	1219.2	152.4

60" RADIUS

Size	Symbol	ØB	R	T	ØB	R	T	
in	mm	inches			millimeters			
	No.							
4	103	22-4031R60	4.190	60	6	106.4	1524.0	152.4
4½	116	22-4531R60	4.730	60	6	120.1	1524.0	152.4
5	129	22-5031R60	5.230	60	6	132.8	1524.0	152.4
6	155	22-6031R60	6.230	60	6	158.2	1524.0	152.4

60" RADIUS

Size	Symbol	ØB	R	T	ØB	R	T	
in	mm	inches			millimeters			
	No.							
4	103	22-4030R60	4.190	60	6	106.4	1524.0	152.4
4½	116	22-4530R60	4.730	60	6	120.1	1524.0	152.4
5	129	22-5030R60	5.230	60	6	132.8	1524.0	152.4
6	155	22-6030R60	6.230	60	6	158.2	1524.0	152.4

72" RADIUS

Size	Symbol	ØB	R	T	ØB	R	T	
in	mm	inches			millimeters			
	No.							
4	103	22-4031R72	4.190	72	6	106.4	1828.8	152.4
4½	116	22-4531R72	4.730	72	6	120.1	1828.8	152.4
5	129	22-5031R72	5.230	72	6	132.8	1828.8	152.4
6	155	22-6031R72	6.230	72	6	158.2	1828.8	152.4

72" RADIUS

Size	Symbol	ØB	R	T	ØB	R	T	
in	mm	inches			millimeters			
	No.							
4	103	22-4030R72	4.190	72	6	106.4	1828.8	152.4
4½	116	22-4530R72	4.730	72	6	120.1	1828.8	152.4
5	129	22-5030R72	5.230	72	6	132.8	1828.8	152.4
6	155	22-6030R72	6.230	72	6	158.2	1828.8	152.4



STANDARD WALL (SW) ACCESSORIES

IPS SW RADIUS BELL END

Size		Symbol No.	ØA ØB		ØA ØB	
in	mm		inches		millimeters	
¾	21	30-7518	1.100	1.535	27.9	39.0
1	27	30-1018	1.210	1.815	30.7	46.1
1¼	35	30-1218	1.300	2.125	33.0	54.0
1½	41	30-1518	1.555	2.510	39.5	63.8
2	53	30-2018	1.575	2.830	40.0	71.9
3	78	30-3018	2.100	4.075	53.3	103.5
4	103	30-4018	2.345	5.250	59.6	133.4
5	129	30-5018	2.375	6.325	60.3	160.7
6	155	30-6018	2.875	7.360	73.0	186.9
8	203	30-8018	3.500	9.643	88.9	244.9

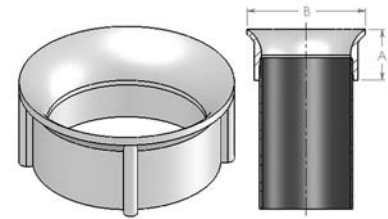

ID SW RADIUS BELL END

Size		Symbol No.	ØA ØB		ØA ØB	
in	mm		inches		millimeters	
2	53	40-2018	1.7	3.0	43.18	76.2
3	78	40-3018	1.7	4.0	43.18	101.6
3½	91	40-3518	1.7	4.5	43.18	114.3
4	103	40-4018	2.2	5.0	55.88	127.0
4½	116	40-4518	2.2	5.5	55.88	139.7
5	129	40-5018	2.2	6.0	55.88	152.4
6	155	40-6018	2.4	7.0	60.96	177.8

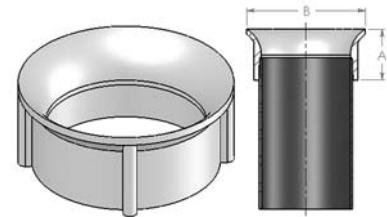

GENERAL ACCESSORIES

IPS THERMOPLASTIC PLUG

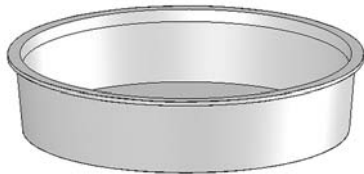

Size		Symbol No.	Depth	
in	mm		in	mm
¾	21	30-7528	0.6	15.2
1	27	30-1028	0.6	15.2
1¼	35	30-1228	0.8	20.3
1½	41	30-1528	0.8	20.3
2	53	30-2028	0.8	20.3
3	78	30-3028	0.8	20.3
4	103	30-4028	1.0	25.4
5	129	30-5028	1.0	25.4
6	155	30-6028	1.5	38.1
8	203	30-8028	1.5	38.1

ID THERMOPLASTIC PLUG

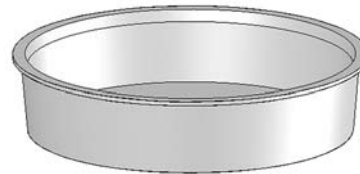

Size		Symbol No.	Depth	
in	mm		in	mm
2	53	40-2028	1.0	25.4
3	78	40-3028	1.0	25.4
3½	91	40-3528	1.0	25.4
4	103	40-4028	1.3	33.0
4½	116	40-4528	1.0	25.4
5	129	40-5028	1.0	25.4
6	155	40-6028	1.5	38.1

THERMOPLASTIC T-STRIP

Size	Symbol No.
All	40-0167

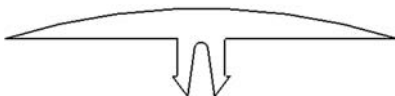

THERMOPLASTIC H-STRIP

Size	Symbol No.
All	40-0169

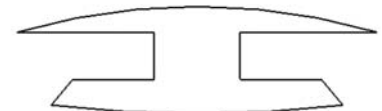

SPLICE & REPAIR KIT

Size	Symbol No.	Conduit size		Length of cut mat		Splices per kit
		in	mm	in	cm	
All	40-0174	2	53	10	25	14
		3	78	12	31	11
		4	103	15	38	9
		5	129	19	48	7
		6	155	23	59	6



ADHESIVE KIT

Size	Symbol No.	
All	40-0161	Epoxy Kit
All	20-0164	Dual Cartridge
All	20-0165	Dual Cartridge Applicator

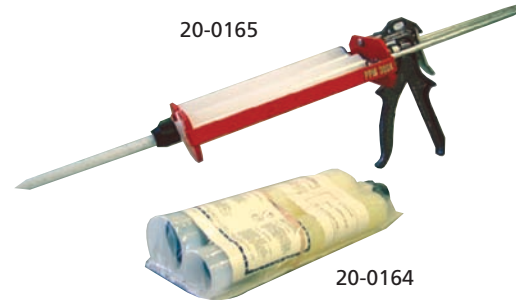

40-0161



MECHANICAL PROPERTIES (40-0161)

Shore D Hardness	81
Tensile strength	3 060 Psi
Lap shear strength	252 Psi
Viscosity	3 700 cP
Mix ratio	2 : 1
Color	Opaque
Solid content	100%

MECHANICAL PROPERTIES (20-0164)

Shore D Hardness	90
Tensile strength	9 900 Psi
Lap shear strength	2 600 Psi
Viscosity	40 000 cP
Mix ratio	2 : 1
Color	Opaque
Solid content	100%

JOINT CALCULATION TABLE (ADHESIVE KIT)

IPS BASED

Size	Joints made per kit	Pull-Out Strength	
		lbs	kg
3/8	28	1 700	771
1	26	2 000	907
1 1/4	24	2 000	907
1 1/2	20	2 000	907
2	16	2 000	907
3	11	3 000	1 360
4	8	4 000	1 814
5	6	5 000	2 268
6	5	6 000	2 722
8	3	8 000	3 628

ID BASED

Size	Joints made per kit	Pull-Out Strength	
		lbs	kg
2	18	2 000	907
2 1/2	16	2 500	1 134
3	13	3 000	1 360
3 1/2	11	3 500	1 587
4	10	4 000	1 814
4 1/2	8	4 500	2 041
5	7	5 000	2 268
6	6	6 000	2 722

MIXER TIP

Size	Symbol No.
All	20-0166



PRODUCT TEST DATA

FRE® Above Ground fiberglass conduit

MATERIAL	TEST RESULTS	TEST PROTOCOL
Resin	Epoxy (no fillers)	
Glass	E-Glass (E- or E-CR-Glass)	CSA C22.2 No. 2515
Toxicity (Toxic Gas Emission)	< 0.2% halogens by weight	UL 2515
PHYSICAL PROPERTIES	TEST RESULTS	TEST PROTOCOL
Glass Content	68% ± 3%	API 15LR
Specific Gravity	1.94 g/cm ³	ASTM D792
Barcol Hardness	54 ± 2	ASTM D2583
U.V. Resistance	> 3 500 Hrs (Xenon Arc)	CSA C22.2 No. 2515
Water Absorption	< 1%	ASTM D570
MECHANICAL DATA	TEST RESULTS	TEST PROTOCOL
Tensile Strength (axial)	≥ 9 000 Psi (62 Mpa)	ASTM D638
Elasticity Modulus (4" (103 mm)	1.3 E6 Psi (8 963 Mpa)	ASTM D2105
TriSeal™ Joint Pull-Out Load	500 lbs (227 kg)	ASTM D2105
Adhesive Joint Pull-Out Load	1 000 lbs per inch trade size	ASTM D2105
SURFACE FINISH	TEST RESULTS	TEST PROTOCOL
Exterior (average)	<2 000 microinches (50.8 micrometers)	
Interior (average)	<125 microinches (3.2 micrometers)	
Color	Black (standard), Other (upon request only)	
THERMAL PROPERTIES	TEST RESULTS	TEST PROTOCOL
Coefficient of Thermal Expansion	1.37 E-5 in./in./°F (2.47 E-5m./m./°C)	ASTM D696
Thermal Conductivity	2 Btu.in/ft ² .h. °F (0.288W/ m.K)	ASTM D335
Thermal Resistivity	0.5°F. ft ² .h/Btu.in (3.47 mK/W)	ASTM D335
Flammability	Article 5.10	UL 2515
Heat Deflection Temperature (HDT)	312°F (156°C)	ASTM D648
ELECTRICAL DATA	TEST RESULTS	TEST PROTOCOL
Dielectric Strength	500 volts/mil (19.68 kV/mm)	ASTM D149
Dielectric Breakdown Voltage	29.7 kV	ASTM D149
Dissipation Factor	0.5%	ASTM D150
COEFFICIENT OF FRICTION	TEST RESULTS	TEST PROTOCOL
Cross Linked Polyethylene Cable	0.233 ± .02	CSA B196.1
PVC Jacketed Cable	0.385 ± .06	CSA B196.1
Concentric Neutral Cable	0.160 ± .03	CSA B196.1
Teck (Armoured) Cable	0.161 ± .03	CSA B196.1

CHEMICAL RESISTANCE

	after 45 days	after 90 days		after 45 days	after 90 days
Sodium chloride, 10% aq. sin.	E	E	Nitric acid, 10% aq. sin.	E	E
Diesel fuel	E	E	Sodium carbonate, 10% aq. sin.	E	E
Unleaded gasoline	E	E	Benzene	NR	NR
Jet fuel	E	E	Toluene	E	E
Hydrochloric acid, 10% aq. sin.	E	E	Xylene	E	E
Sulfuric acid, 10% aq. sin.	E	E	Acetone	NR	NR

E: excellent chemical resistance

NR : not recommended for long term contact.

Note : Chemical resistance tests reported here were conducted according to UL-651 section 38. Samples were immersed in the specified chemical reagent for 45 and 90 days, respectively. Weight gains or weight losses at the end of the immersion period were recorded. Mechanical integrity was determined by the parallel plate crush (ASTM D2412) test. Loads were measured at 5% deflection and at failure at the end of the immersion period and compared to the reference values of control specimens not exposed to any chemical attack. Weight gains or losses above 2% and drops in crushing resistance (load at 5% deflection or load at failure) above 15% were considered as evidence of insufficient chemical resistance.



REPRESENTATIVE PERFORMANCE SPECS

Size in	mm	Wall		Weight		Failure Load (ASTM D2412)		Impact (ASTM D2444)		Field Bending Radius at 0.2% strain		Moment of inertia	
		in	mm	lbs/ft.	Kg/m	lbs/ft.	Kg/m	lbs ft.	Kg m	ft.	m	in ⁴	cm ⁴
IPS STANDARD WALL (SW)													
¾	21	.066	1.7	.17	.25	5 000	7 439	25	3.46	42	13	0.024	1.0
1	27	.066	1.7	.22	.32	4 200	6 249	30	4.15	42	13	0.050	2.1
1¼	35	.066	1.7	.28	.41	3 800	5 654	30	4.15	46	14	0.103	4.3
1½	41	.066	1.7	.32	.46	3 500	5 207	35	4.84	54	16	0.157	6.5
2	53	.070	1.8	.42	.63	3 000	4 463	80	11.07	68	21	0.337	14.0
3	78	.070	1.8	.63	.94	2 300	3 422	120	16.60	100	30	1.110	46.2
4	103	.070	1.8	.82	1.22	2 000	2 976	160	22.14	132	40	2.390	99.5
5	129	.095	2.4	1.39	2.07	3 000	4 463	200	27.67	160	49	6.101	253.9
6	155	.110	2.8	1.89	2.82	2 800	4 166	240	33.21	190	58	11.948	478.6
8	203	.115	2.9	2.61	3.88	2 400	3 571	280	38.75	235	72	27.818	1157.9

IPS HEAVY WALL (HW)													
4	103	.095	1.8	.82	1.22	n/a	n/a	160	22.14	n/a	n/a	3.300	137.4
5	129	.115	2.4	1.39	2.07	n/a	n/a	200	27.68	n/a	n/a	7.468	310.8
6	155	.115	2.8	1.89	2.82	n/a	n/a	240	33.22	n/a	n/a	12.521	521.2

ID STANDARD WALL (SW)													
2	53	.070	1.8	.38	.57	3 200	4 761	60	8.30	68	21	0.244	10.2
2½	63	.070	1.8	.48	.71	2 700	4 017	80	11.06	80	24	0.467	19.4
3	78	.070	1.8	.57	.85	2 400	3 571	120	16.60	100	30	0.796	33.1
3½	91	.070	1.8	.66	.98	2 200	3 273	140	19.37	116	35	1.251	52.1
4	103	.070	1.8	.75	1.12	2 100	3 124	160	22.14	132	40	1.854	77.2
4½	116	.095	2.4	1.16	1.72	3 400	5 059	180	24.90	150	46	3.621	150.7
5	129	.095	2.4	1.28	1.90	3 800	5 654	200	27.67	166	51	4.936	205.4
6	155	.095	2.4	1.53	2.28	3 600	5 356	200	27.67	198	60	8.449	351.7

ID HEAVY WALL (HW)													
4	103	.095	2.4	1.03	1.53	n/a	n/a	160	22.14	n/a	n/a	2.563	106.7
4½	116	.115	2.4	1.16	1.72	n/a	n/a	180	24.91	n/a	n/a	4.442	184.9
5	129	.115	2.4	1.28	1.90	n/a	n/a	200	27.68	n/a	n/a	6.047	251.7
6	155	.115	2.4	1.53	2.28	n/a	n/a	200	27.68	n/a	n/a	10.330	429.9

Note: Impact resistance tests were carried out at -40°C, as required by UL 2515/CSA C22.2 No. 2515, and at 23°C. The values reported here are the lowest of the two measurements (normally those taken at -40°C).

n/a: not available, please consult FRE Composites for details.

FLEXURAL DATA

Maximum flexural Modulus:	1.4E6 Psi	9 653 Mpa
Allowable working stress at 0,2% strain:	2 800 Psi	19.31 Mpa
Maximum long term flexural modulus at 0,2% strain:	1E6 Psi	6 895 Mpa
Long term allowable design stress:	2 000 Psi	13.79 Mpa

CONDUIT DEFLECTION TABLES

The graphs on the following pages reflect the span-deflection characteristics of FRE® Conduit. First, select the appropriate deflection graph. Continue by selecting the appropriate cable weight from the X-axis and move in a vertical direction, intercepting various deflection lines. At the appropriate deflection line for your application, look left the chart to find the recommended span between supports.

In order to take long-term creep into account, the charts have been tabulated using the long-term modulus in the calculations. Because of this, conduit sections will actually deflect much less than the charted value when first installed. If this long-term safety margin is not required, FRE Composites will prepare appropriate span charts for your application on request.

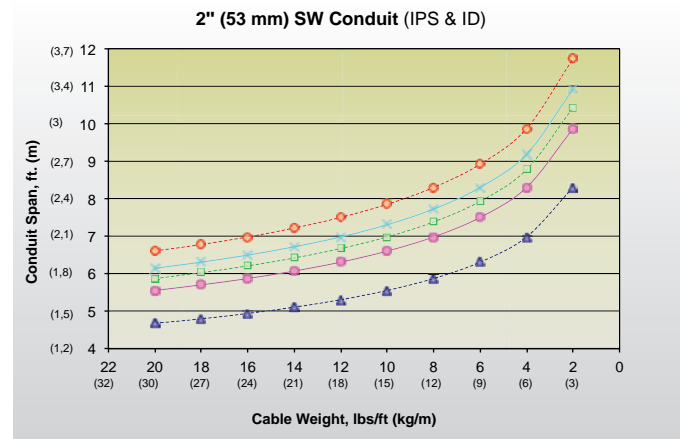
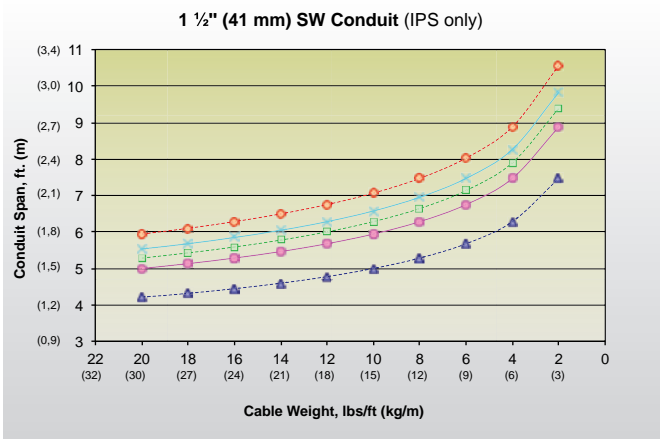
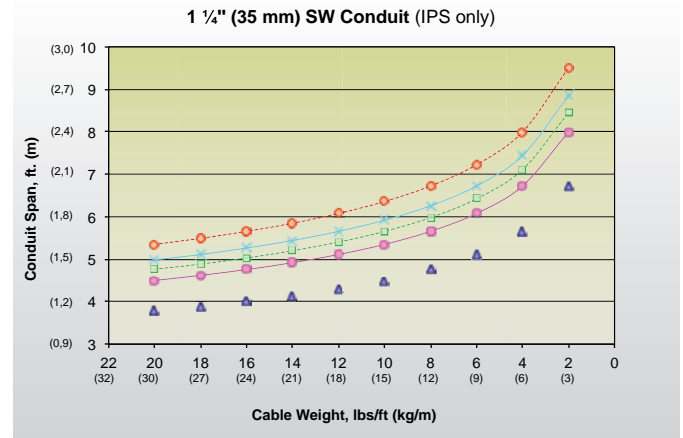
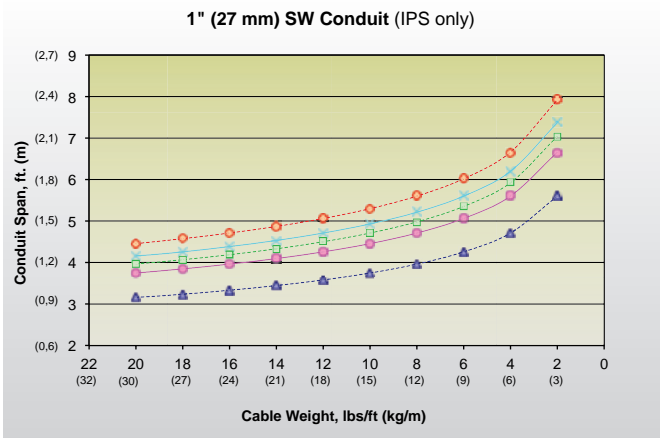
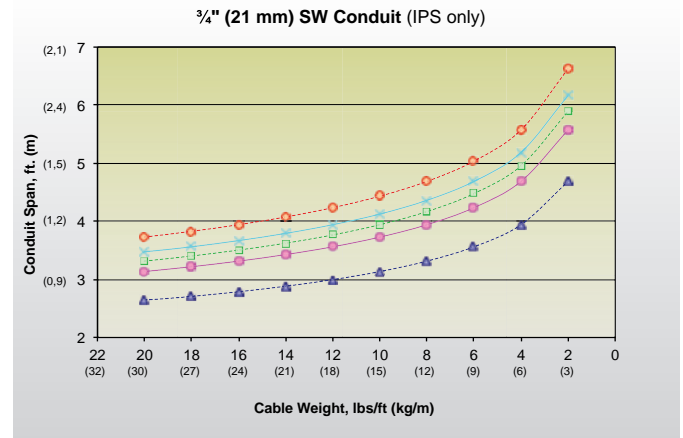

---▲--- 1/4" (6mm) Deflection —●— 1/2" (13mm) Deflection - - -■- - - 5/8" (16mm) Deflection —×— 3/4" (19mm) Deflection - - -◇- - - 1" (25mm) Deflection

CONDUIT DEFLECTION TABLES (CONTINUED)

2 1/2" (63 mm) SW Conduit (IPS & ID)

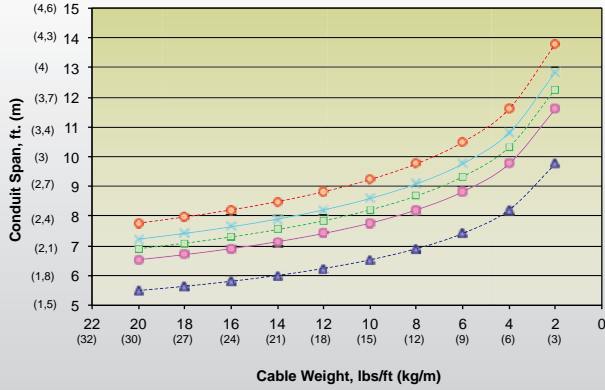

3" (78 mm) SW Conduit (IPS & ID)

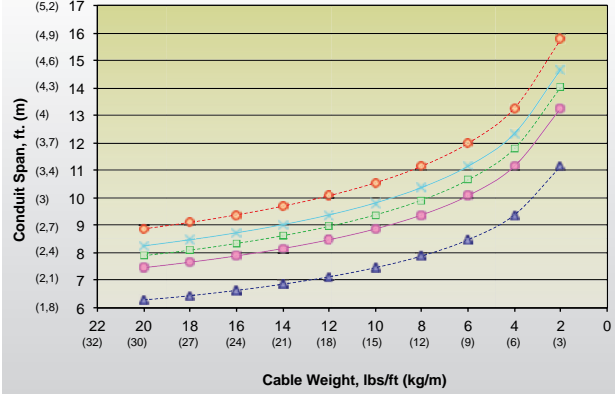

3 1/2" (91 mm) SW Conduit (ID only)

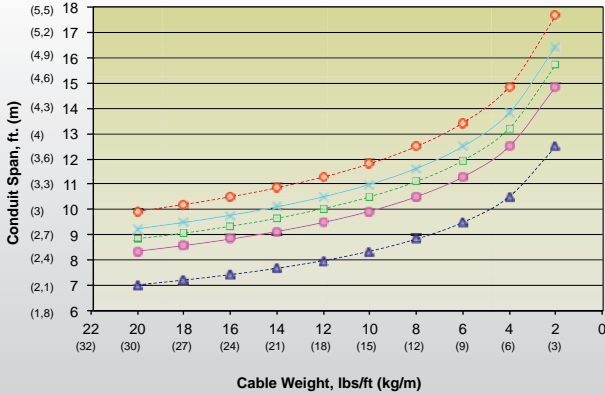

4" (103 mm) SW Conduit (IPS & ID)

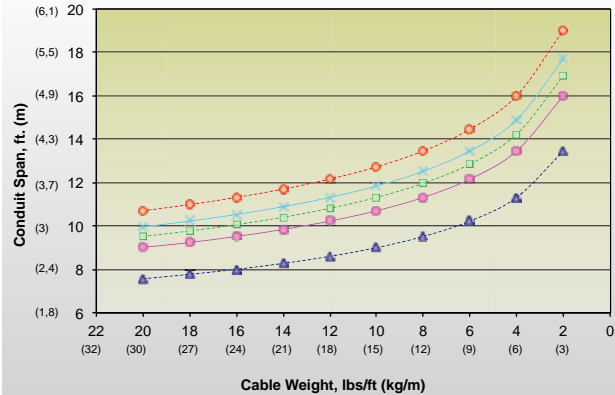

4 1/2" (116 mm) SW Conduit (ID only)

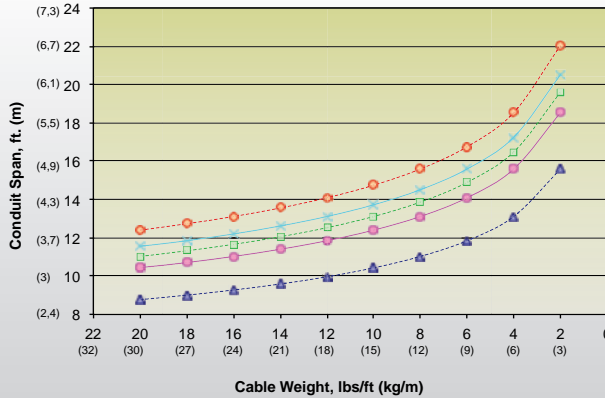

5" (129 mm) SW Conduit (IPS & ID)

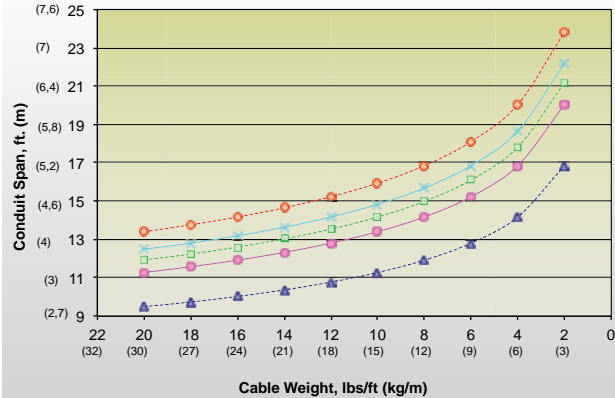

---▲--- 1/4" (6mm) Deflection ---●--- 1/2" (13mm) Deflection ---■--- 5/8" (16mm) Deflection ---×--- 3/4" (19mm) Deflection ---◇--- 1" (25mm) Deflection

CONDUIT DEFLECTION TABLES (CONTINUED)

6" (155 mm) SW Conduit (IPS & ID)

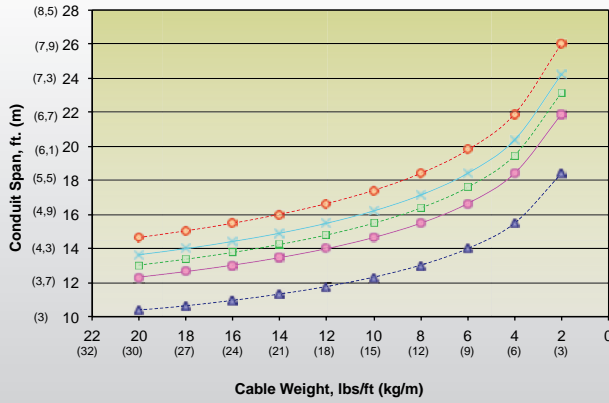

8" (203 mm) SW Conduit (IPS only)

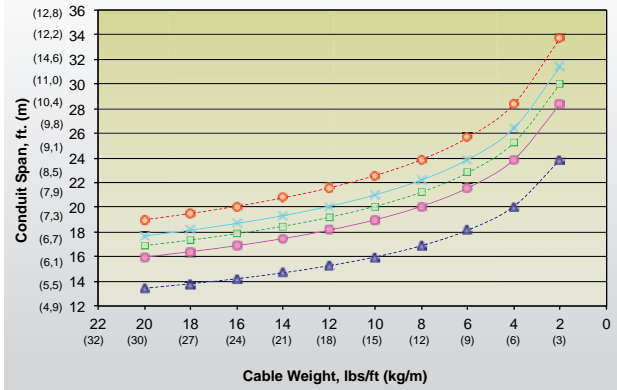

4" (103 mm) HW Conduit (IPS & ID)

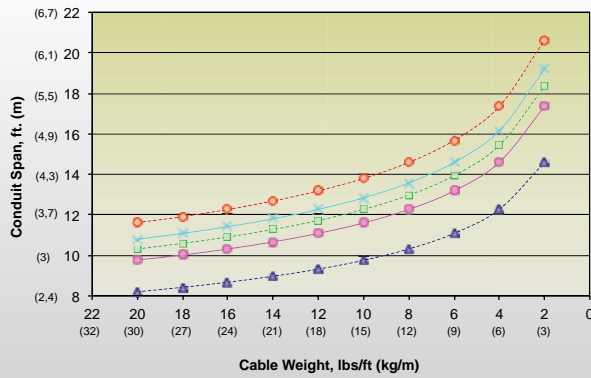

4 1/2" (116 mm) HW Conduit (ID only)

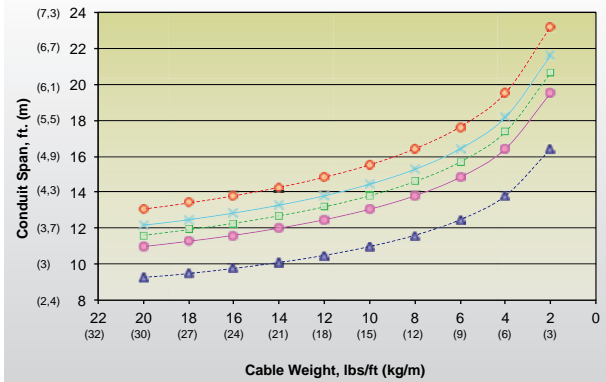

5" (129 mm) HW Conduit (IPS & ID)

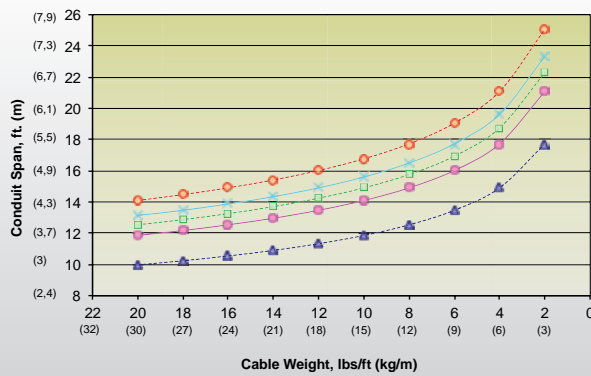

6" (155 mm) HW Conduit (IPS & ID)

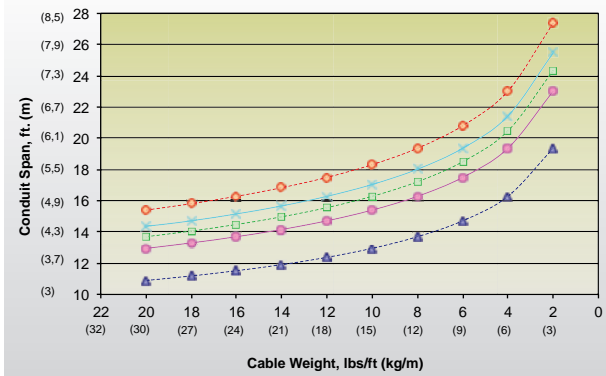

---▲--- 1/4" (6mm) Deflection —●— 1/2" (13mm) Deflection - - -■ - - - 5/8" (16mm) Deflection —×— 3/4" (19mm) Deflection - - -◇ - - - 1" (25mm) Deflection

PULLING TENSION FOR CABLES

The cable manufacturer must be consulted for the maximum pull permitted on a selected cable. Other data such as lubrication restrictions should also be obtained from the cable manufacturer. The total pulling force required for a cable in a conduit depends upon the cable weight, length of conduit, number and location of the elbows and the coefficient of friction of friction.

The following formula is published to aid in obtaining tension values: $T_i = T_{i-1}e^{\left(\frac{fa}{180}\right)} + wL \cos \phi + wL \sin \phi$

- T_i = Tension at the point towards end of run (lbs)
- f = Coefficient of friction
- L = Length of conduit subjected to cable weight (ft.)
- e = Napirian Logarithm base = 2.718
- T_{i-1} = Tension at point towards beginning of run (lbs)
- w = Cable weight per foot (lbs/ft.)
- a = Elbow angle ($^\circ$)
- ϕ = Angle ($^\circ$) of run with regards to the horizontal
 - positive if run moves upwards
 - negative if run moves downwards
 - equal zero (0) if run is horizontal

Example:

Parameters - $f = .25$ $w = 10$ lbs/ft. $r = 36$ inches = Elbow radius (used to calculate elbow length)

i) Pulling from point "0" to point "7"

Point i	ϕ ($^\circ$)	a ($^\circ$)	L (ft.)	$e^{\left(\frac{fa}{180}\right)}$	T_i (lbs)
0	-	-	-	-	0.0
1	0.0	0.0	10.0	1.00	25.00
2	0.0	45.0	3.4	1.22	38.81
3	0.0	0.0	5.0	1.00	51.31
4	0.0	45.0	3.4	1.22	70.84
5	0.0	0.0	8.0	1.00	90.84
6	0.0	90.0	5.7	1.48	148.81
7	0.0	0.0	3.0	1.00	156.31

ii) Pulling from point "7" to point "0"

Point i	ϕ ($^\circ$)	a ($^\circ$)	L (ft.)	$e^{\left(\frac{fa}{180}\right)}$	T_i (lbs)
7	-	-	-	-	0.0
6	0.0	0.0	3.0	1.00	7.50
5	0.0	90.0	5.7	1.48	25.39
4	0.0	0.0	8.0	1.00	45.39
3	0.0	45.0	3.4	1.22	63.63
2	0.0	0.0	5.0	1.00	76.13
1	0.0	45.0	3.4	1.22	101.03
0	0.0	0.0	10.0	1.00	126.03

ϕ : This value is always zero until the run is directed other than completely horizontal.

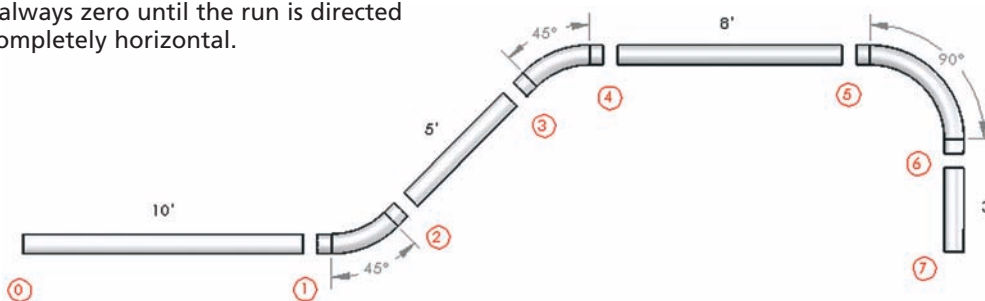

The following table is published to aid in solving the values for $e^{\left(\frac{fa}{180}\right)}$

Elbow Angle($^\circ$)	For f = 0.25	For f = 0.35	For f = 0.45	For f = 0.55
11.25 $^\circ$	1.050	1.071	1.092	1.114
22.5 $^\circ$	1.103	1.147	1.193	1.241
30 $^\circ$	1.140	1.201	1.266	1.334
45 $^\circ$	1.217	1.316	1.424	1.540
60 $^\circ$	1.299	1.443	1.602	1.779
90 $^\circ$	1.481	1.733	2.028	2.372

MAXIMUM TENSION ALLOWED AT ELBOWS:

The maximum pulling tension at a elbow must not exceed the calculated value of $300 \times r$ (Radius of the conduit elbow in feet). The above equations are used to determine what tension will occur at a elbow. This is to avoid cable damage.* In general, it is preferred to pull in the direction which results in the lowest tension. To do this, the pay-off reel should be placed at the end nearest the elbow.

*For safe pulling tension, to avoid cable damage, consult cable manufacturers for tension per cable type.

WIRE FILL

Maximum allowable percentage wire fill from 2008 National Electrical Code (NEC) and 2012 Canadian Electrical Code (CEC).

IPS SIZES

IMPERIAL					
Trade size IPS	Inside Diameter (in)	Total Area 100% (in ²)	NUMBER OF CONDUCTORS & Percent of cross section of conduit for conductors		
			1 53% fill (in ²)	2 31% fill (in ²)	Over 2 40% fill (in ²)
¾	0.918	0.662	0.351	0.205	0.265
1	1.183	1.099	0.583	0.341	0.440
1¼	1.528	1.834	0.972	0.568	0.733
1½	1.768	2.455	1.301	0.761	0.982
2	2.235	3.923	2.079	1.216	1.569
3	3.360	8.867	4.699	2.749	3.547
4	4.360	14.930	7.913	4.628	5.972
5	5.373	22.674	12.017	7.029	9.070
6	6.405	32.220	17.077	9.988	12.888
8	8.395	55.352	29.336	17.159	22.141

METRIC					
Trade size IPS	Inside Diameter (mm)	Total Area 100% (mm ²)	NUMBER OF CONDUCTORS & Percent of cross section of conduit for conductors		
			1 53% fill (mm ²)	2 31% fill (mm ²)	Over 2 40% fill (mm ²)
21	23	427	226	132	171
27	30	709	376	220	284
35	39	1183	627	367	473
41	45	1584	839	491	634
53	57	2531	1 341	785	1 012
78	85	5721	3 032	1 773	2 288
103	111	9632	5 105	2 986	3 853
129	136	14 628	7 753	4 535	5 851
155	163	20 787	11 017	6 444	8 315
203	213	35 711	18 927	11 070	14 284

ID SIZES

IMPERIAL					
Trade size ID	Inside Diameter (in)	Total Area 100% (in ²)	NUMBER OF CONDUCTORS & Percent of cross section of conduit for conductors		
			1 53% fill (in ²)	2 31% fill (in ²)	Over 2 40% fill (in ²)
2	2.000	3.142	1.665	0.974	1.257
2½	2.500	4.909	2.602	1.522	1.964
3	3.000	7.069	3.746	2.191	2.827
3½	3.500	9.621	5.099	2.983	3.848
4	4.000	12.566	6.660	3.896	5.027
4½	4.500	15.904	8.429	4.930	6.362
5	5.000	19.635	10.407	6.087	7.854
6	6.000	28.274	14.985	8.765	11.310

METRIC					
Trade size ID	Inside Diameter (mm)	Total Area 100% (mm ²)	NUMBER OF CONDUCTORS & Percent of cross section of conduit for conductors		
			1 53% fill (mm ²)	2 31% fill (mm ²)	Over 2 40% fill (mm ²)
53	53	2 027	1 074	628	811
63	63	3 167	1 678	982	1 267
78	78	4 560	2 417	1 414	1 824
91	91	6 207	3 290	1 924	2 483
103	103	8 107	4 297	2 513	3 243
116	116	10 261	5 438	3 181	4 104
129	129	12 668	6 714	3 927	5 067
155	155	18 242	9 668	5 655	7 297



GLOSSARY

FRE® Conduit

Fiberglass **R**einforced **E**poxy conduit manufactured by FRE Composites. **FRE®** is a registered trademark in Canada, United States and elsewhere in the world, and is a recognized name worldwide since 1970's for superior quality advanced composite products.

IPS (Iron Pipe Size)

Dimensional standard widely utilized in North America for both metallic (such as RMC, EMT, IMC) and Rigid Non metallic (RTRC, PVC and HDPE) electrical conduit. This trade size has established its Outside Diameter as the constant value.

ID (Inside Diameter)

Dimensional standard widely utilized in North America for electrical and telecommunication raceways. This trade size has established its Inside Diameter as the constant value.

Thin Wall (TW) conduit for Below Ground (BG) Encased Burial (EB) applications

Conduit built with a reduced nominal wall thickness that varies based on the conduit diameter.

Standard Wall (SW) conduit for Below Ground (BG) typical Direct Burial (DB) or Encased Burial (EB) installations or for typical Above Ground (AG) exposed applications

Conduit built with a standard nominal wall thickness that varies based on the conduit diameter.

Heavy Wall (HW) conduit for Below Ground (BG) heavy loads Direct Burial (DB) or for Above Ground (AG) enhanced mechanical properties

Conduit built with a heavier nominal wall thickness that varies based on the conduit diameter.

Extra Heavy Wall (XHW) conduit

Conduit built with a constant nominal wall thickness of 0.250" (6,4 mm) not withstanding variation on conduit diameter.

RTRC (Reinforced Thermosetting Resin Conduit)

An industry acronym for conduits that are manufactured using a mineral reinforcement such as fiberglass in a fully cured thermoset resin.

Specification Grade

IPS or ID conduit system products manufactured to FRE Composites' own specification.

Conduit

Straight section available in 9.84 ft (3m) or 19.68 ft (6m) length, and in standard diameters from ¾" to 8" (21 to 203 mm).

TriSeal™ gasket

Injection moulded elastomeric TriSeal™ is designed to simultaneously offer a 500 pounds (227 kg) pullout strength once properly assembled and ensure adequate joint water tightness between FRE® conduit sections. It consists of a one-piece flexible gasket with a triple indentation.

Key Products

Split conduit (Patented design)

Section of FRE® conduit cut completely on its longitudinal axis while being hinged at 180° to the longitudinal cut. It can be opened and closed, allowing its installation over existing cables to protect them without having to remove them. The original Split conduit invention was issued to General Electric of Canada (CGE), our former parent company, under U.S. Patent No. 4175593 and Canadian Patent No. 1043277

H strip

Thermoplastic strip utilized to seal the split side of a split conduit.

T strip

Thermoplastic strip utilized to seal the hinged side of a split conduit.

Sleeve

Oversized section (12" or 305 mm in length) of straight conduit used to repair a damage section of a conduit.

Wobble coupling

Non-watertight fitting allowing for vertical and horizontal movements ($\pm 3^\circ$) of the raceway.

Skew Wobble coupling

Non-watertight fitting allowing for vertical and horizontal movements ($\pm 7.5^\circ$) of the raceway.

O-Ring Expansion Joint

Section of conduit including a deep socket unthreaded female section and a gasketed male section of conduit. It is designed to accommodate the thermal expansion and contraction of long sections of straight conduit resulting from ambient temperature variation. This guarantees the water tightness of the joint and no dislocation of the fitting.

O-Ring Expansion/Deflection Joint

Similar to O-Ring expansion joint described above, but designed to accommodate slight vertical changes in the direction of the incoming conduit by means of a flexible neoprene sleeve located at the exit of the expansion joint.

Conduit body

Moulded fitting designed to contain cable splices or permit directional changes, having several outlets designed to fit onto straight conduit sections and a sealed, removable cover allowing access to the cables inside the box. Such fittings are available in different types and different diameter trade sizes.

Riserway

Straight section of increased wall thickness (0.235") (6 mm) conduit to protect the cable along a distribution pole.

Hangers (Intermediate or Anchored)

Corrosion protected metallic supports utilized to hang conduit raceways in above ground installations.

Key Technical Descriptions

Glass content

Weight percent of glass fiber present in the conduit, as % of total weight.

Span distance

Distance between conduit supports which varies based on the selected cable weight and conduit trade size.

Deflection

Deformation of conduit due to the weight of the cable installed inside it. Deflection is a function of the diameter and weight of the cables, and of the distance between conduit supports. Measured in inches.

Coefficient of thermal expansion

Ratio representing the change in linear dimension of a section of conduit resulting from changes in temperature (ΔT°).

Coefficient of friction

Ratio of the force tending to maintain contact between two surfaces and the force which opposes the sliding of the surfaces one along the other.

STANDARD CONDUIT PACKAGING

IPS STANDARD WALL (SW)																			
Size		Length		Weight per Stick		Weight per Crate		Sticks per Crate	Footage per Crate		Crate per Truck	Footage per Truck		Weight per Truck		Width per Crate		Height per Crate	
in	mm	ft	meter	lb	kg	lb	kg		ft	meter		ft	meter	lb	kg	in	mm	in	mm
¾	21	9.84	3	1.5	0.68	307	139	200	1 968	600	80	157 440	47 988	24 560	11 140	45	1 143	8	203
1	27	9.84	3	2.20	1.00	337	153	150	1 476	450	80	118 080	35 991	26 960	12 229	45	1 143	10	254
1 ¼	35	9.84	3	2.60	1.18	397	180	150	1 476	450	80	118 080	35 991	31 760	14 406	45	1 143	10	254
1 ½	41	9.84	3	3.10	1.41	472	214	150	1 476	450	80	118 080	35 991	37 760	17 128	45	1 143	10	254
2	53	19.68	6	8.80	3.99	596	270	66	1 299	396	40	51 955	15 836	23 832	10 810	45	1 143	10	254
3	78	19.68	6	13.10	5.94	1 076	488	81	1 594	486	16	25 505	7 774	17 218	7 810	45	1 143	24	610
4	103	19.68	6	16.90	7.67	742	336	43	846	258	16	13 540	4 127	11 867	5 383	45	1 143	24	610
5	129	19.68	6	28.30	12.84	864	392	30	590	180	16	9 446	2 879	13 824	6 271	45	1 143	24	610
6	155	19.68	6	39.00	17.69	795	361	20	394	120	16	6 298	1 920	12 720	5 770	45	1 143	24	610
8	203	19.68	6	53.30	24.18	548	249	10	197	60	16	3 149	960	8 768	3 977	45	1 143	24	610

IPS HEAVY WALL (HW)																			
Size		Length		Weight per Stick		Weight per Crate		Sticks per Crate	Footage per Crate		Crate per Truck	Footage per Truck		Weight per Truck		Width per Crate		Height per Crate	
in	mm	ft	meter	lb	kg	lb	kg		ft	meter		ft	meter	lb	kg	in	mm	in	mm
4	103	19.68	6	23.00	10.43	1 004	455	43	846	258	16	13 540	4 127	16 064	7 287	45	1 143	24	610
5	129	19.68	6	34.30	15.56	1 044	474	30	590	180	16	9 446	2 879	16 704	7 577	45	1 143	24	610
6	155	19.68	6	40.80	18.51	831	377	20	394	120	16	6 298	1 920	13 296	6 031	45	1 143	24	610

ID STANDARD WALL (SW)																			
Size		Length		Weight per Stick		Weight per Crate		Sticks per Crate	Footage per Crate		Crate per Truck	Footage per Truck		Weight per Truck		Width per Crate		Height per Crate	
in	mm	ft	meter	lb	kg	lb	kg		ft	meter		ft	meter	lb	kg	in	mm	in	mm
2	53	19.68	6	6.81	3.09	519	235	74	1 456	444	40	58 253	17 756	20 758	9 416	45	1 143	10	254
2½	63	19.68	6	8.40	3.81	1 317	597	155	3 050	930	16	48 806	14 876	21 072	9 558	45	1 143	24	610
3	78	19.68	6	11.24	5.10	1 139	517	100	1 968	600	16	31 488	9 598	18 224	8 266	45	1 143	24	610
3½	91	19.68	6	12.80	5.81	962	436	74	1 456	444	16	23 301	7 102	15 395	6 983	45	1 143	24	610
4	103	19.68	6	15.18	6.89	880	399	57	1 122	342	16	17 948	5 471	14 084	6 389	45	1 143	24	610
4½	116	19.68	6	20.70	9.39	905	411	43	846	258	16	13 540	4 127	14 482	6 569	45	1 143	24	610
5	129	19.68	6	25.22	11.44	973	442	38	748	228	16	11 965	3 647	15 574	7 064	45	1 143	24	610
6	155	19.68	6	31.30	14.20	829	376	26	512	156	16	8 187	2 495	13 261	6 015	45	1 143	24	610

ID HEAVY WALL (HW)																			
Size		Length		Weight per Stick		Weight per Crate		Sticks per Crate	Footage per Crate		Crate per Truck	Footage per Truck		Weight per Truck		Width per Crate		Height per Crate	
in	mm	ft	meter	lb	kg	lb	kg		ft	meter		ft	meter	lb	kg	in	mm	in	mm
4	103	19.68	6	22.00	9.98	1 269	576	57	1 122	342	16	17 948	5 471	20 304	9 210	45	1 143	24	610
4 ½	116	19.68	6	28.00	12.70	1 219	553	43	846	258	16	13 540	4 127	19 504	8 847	45	1 143	24	610
5	129	19.68	6	32.00	14.52	1 231	558	38	748	228	16	11 965	3 647	19 696	8 934	45	1 143	24	610
6	155	19.68	6	39.00	17.69	1 029	467	26	512	156	16	8 187	2 495	16 464	7 468	45	1 143	24	610

Standard Accessories Packaging														Ordering in multiple of standard packaging is highly recommended.		
Product	Size		Amount	Package	Product	Size		Amount	Package	Product	Size		Amount	Package		
	in	mm				in	mm				in	mm				
Coupling	2	53	20	Bag	O-Ring	2	53	10	Bag	Adapters	2	53	20	Bag		
Coupling	3-5	78-129	10	Bag	O-Ring	3-5	78-129	5	Bag	Adapters	3-6	78-155	10	Bag		
Coupling	6	155	8	Bag	Reducers			10	Bag	Elbows	1-2	27-53	10	Bundle		
Wobble	2	53	10	Bag	Expansion JT	2-6	53-129	5	Bundle	Bends	3-6	78-155	5	Bundle		
Wobble	3-6	78-129	5	Bundle	Adapters	1-1½	27-41	50	Bag	Bell Ends			A/R	Carton		



Printed in Canada



75 WALES STREET
ST-ANDRE-D'ARGENTEUIL (QUEBEC)
CANADA J0V 1X0
TELEPHONE: +1 450 537-3311
FAX: +1 450 537-3415
TOLL FREE: 888 849-9909

FRE
COMPOSITES®

WWW.FRECOMPOSITES.COM



60 GREENHORN DRIVE
PUEBLO CO 81004
TELEPHONE: +719-565-3311
FAX: +719-564-3415
TOLL FREE: 888 849-9909